

**Safety From Falling Barriers**

**Base Fix PG120B - SAFELITE laminated toughened safety glass and TEMPAFLOAT monolithic toughened safety glass. Steel and concrete only**

Glass Thickness t (mm)	Occupancy	Maximum Design Height H (mm)	Channel Fixing Spacing (mm) Max	Design loads to deck structure			
				M* (kNm/m)	T* (kN)	SLS Wind (kPa)	ULS Wind (kPa)
12, 13.52, 15.2, 15, 17.52 & 17.2	A	1150	400	1.04	12.94	-	-
	C3/B/E	1000	400	1.13	14.06	1.51	2.25
		1100	400	1.24	15.47	1.37	2.05
		1150	400	1.29	16.17	1.31	1.96
19.2	C3/B/E	1220	200	1.37	8.58	1.24	1.84
15, 17.52	C3/B/E	1250	200	1.41	8.79	1.21	1.80
21.52	C1/C2/D	1250	200	2.81	17.58	2.41	3.60

**Side Fix PG120S & PG180S - SAFELITE laminated toughened safety glass and TEMPAFLOAT monolithic toughened safety glass. Steel, concrete and timber**

Glass Thickness t (mm)	Occupancy	Maximum Design Height H (mm)	Channel Fixing Spacing (mm) Max	Design loads to deck structure			
				M* (kNm/m)	T* (kN)	SLS Wind (kPa)	ULS Wind (kPa)
12, 13.52, 15.2, 15, 17.52 & 17.2	A	1030	400	0.93	8.48	-	-
	C3/B/E	1030 (concrete/steel)	400	1.33	13.33	1.68	2.50
		1030 (timber)	200	1.33	6.67	1.68	2.50
	19.2	C3/B/E	1100*	200	1.41	6.96	1.56
17.52	C3/B/E	1130 (concrete/steel)	200	1.44	7.09	1.51	2.26
21.52	C1/C2/D	1130 (concrete/steel)	200	2.88	14.18	3.02	4.51

Note: 1) Maximum design height (H) for fixing to timber is 1050mm  
2) Balustrades for C1, C2 & D Occupancy are not suitable for fixing to timber.

**Base Fix Free Standing Pool Fences (not protecting a fall of 1.0m or more). Steel and concrete only.**

Glass Thickness t (mm)	NZS3604 Wind Zone	Substrate	Maximum Design Height H (mm)	Channel Fixing Spacing (mm) Max	Design loads to deck structure	
					M* (kNm/m)	T* (kN)
12	Up to High	Concrete, Steel	1220	400	0.86	10.75
15	Very High	Concrete, Steel	1220	200	1.11	6.94
17.52	Extra High	Concrete, Steel	1220	200	1.34	8.38

**Side Fix Free Standing Pool Fences (not protecting a fall of 1.0m or more). Steel, Concrete and Timber**

Glass Thickness t (mm)	NZS3604 Wind Zone	Substrate	Maximum Design Height H (mm)	Channel Fixing Spacing (mm) Max	Design loads to deck structure	
					M* (kNm/m)	T* (kN)
12	Up to High	Concrete, Steel, Timber	1220	400	1.01	9.75
15	Very High	Concrete, Steel, Timber	1220	200	1.30	6.27
17.52	Extra High	Concrete, Steel	1220	200	1.57	7.58

**Glass thickness key:**

Glass Thickness t (mm)	Inner layer <sup>3</sup> glass thickness (mm)	Interlayer thickness (mm) and type	Outer layer glass thickness (mm)	Panel size requirements	
				Minimum panel width (mm)	Maximum panel width (mm)
12	-	-	-	1000	1700/1900 (see below)
13.52	6	1.52 SAFELITE STF	6	1700	Refer manufacturing limits
15.2	8	1.2 SAFELITE EVA	6	1000	1700/1900 (see below)
15	-	-	-	1000	1700/1900 (see below)
17.52	8	1.52 SAFELITE STF	8	1100	Refer manufacturing limits
17.2	8	1.2 SAFELITE EVA	8	1000	1700/1900 (see below)
19.2	10	1.2 SAFELITE EVA	8	1000	1700/1900 (see below)
21.52	10	1.52 SAFELITE STF	10	1100	Refer manufacturing limits

Note: 3) Inner layer refers to balcony side

**Maximum panel widths for Interlinking Rail/Bracket systems:**

Applies where barrier is protecting a fall of 1.0m or more

Interlinking Rail System	Maximum panel width (mm)	Position
S25	1700	on glass only
S40	1700/1900	HB50 bracket/on glass
Edgetec	1700/1900	HB50 bracket/on glass
MFG SB Bracket on SAFELITE only	1900	200mm from top of glass

**Post failure requirements:**

Applies where barrier is protecting a fall of 1.0m or more

TEMPAFLOAT	Interlinking rail required in all cases
SAFELITE EVA	Interlinking rail or SB brackets required all cases
SAFELITE STF	No interlinking rail required, minimum panel widths apply

**NOTES**

Refer to elevation drawings for Height 'H'

The specifier must ensure the balustrade height above floor level requirements as per the NZ Building Code are complied with.

Design loads are in accordance with AS/NZS 1170.1:2002 table 3.3 and NZBC B1/VM1 and DBH Guidance on Barrier Design (March 2012).

M\* & T\* denote bending moment (kNm/m width) and tension loads (kN/connection) respectively to be supported by the deck/pool structure.

Capacity of all substructure is to be verified by building engineer or checked for accordance with NZS3604 (where applicable) prior to fixing

Fixing centres in tables above are applicable to concrete, steel and (where allowed) timber. Refer to fixing detail drawings for further details.

All glass is to be toughened safety glass supplied by Metro Performance Glass, in either TEMPAFLOAT Monolithic, SAFELITE EVA Laminated or SAFELITE STF Laminated variants subject to requirements of the tables above.

Glass & interlayer thicknesses shown are nominal thickness. Table is based on glass minimum tolerance as per NZS 4223.1:2008.

Refer to the relevant fixing details on drawings: PG120B/C/RA(M10), PG120B/C/RA(M12), PG120B/S/BN, PG120S-180S/C/RA(M10),

PG120S-180S/C/RA(M12) and PG120S-180S/S/BN, PG120S-180S/T/BN, PG120S-180S/T/CS

Design table only valid for use with PosiGlaze balustrade system.

SLS Deflection in this instance is above recommended limit of 30mm excluding rotation in the supporting structure.

In all cases the posiglaze channel must be fixed with EPDM layer directly to the relevant supporting structure.

For designs outside the scope of these tables and ULS wind pressures exceeding those shown, specific design is required.

Minimum glass strength 100MPa, all edges polished

Maximum 10mm tolerance allowed to H heights noted in table

Monolithic glass options only applicable for situations where all parts of glazing are within 5000mm of adjacent lower floor/ground below

Pool fences listed above refer to free standing structures where safety from falling is not applicable, design is based on Importance Level 1

# PosiGlaze PG120B Balustrade System CONCRETE Fixing Detail

Drawing No.: PG120B/C/RA (M10)  
 Revision: R10  
 Fixing Type: PG120 with rod anchor (M10)  
 Occupancy: A, B, E, C3  
**NOT SUITABLE FOR OCCUPANCY C1/C2, D OR C5**

Refer to PosiGlaze balustrade system design table for required glass thickness, fixing spacings and fixing loads according to AS/NZS 1170.1:2002 for the occupancies listed above.

**NOTES:** Refer to design tables and elevations for post failure requirements. Interlinking rail / clips not shown for clarity. 'H' refers to top of barrier.

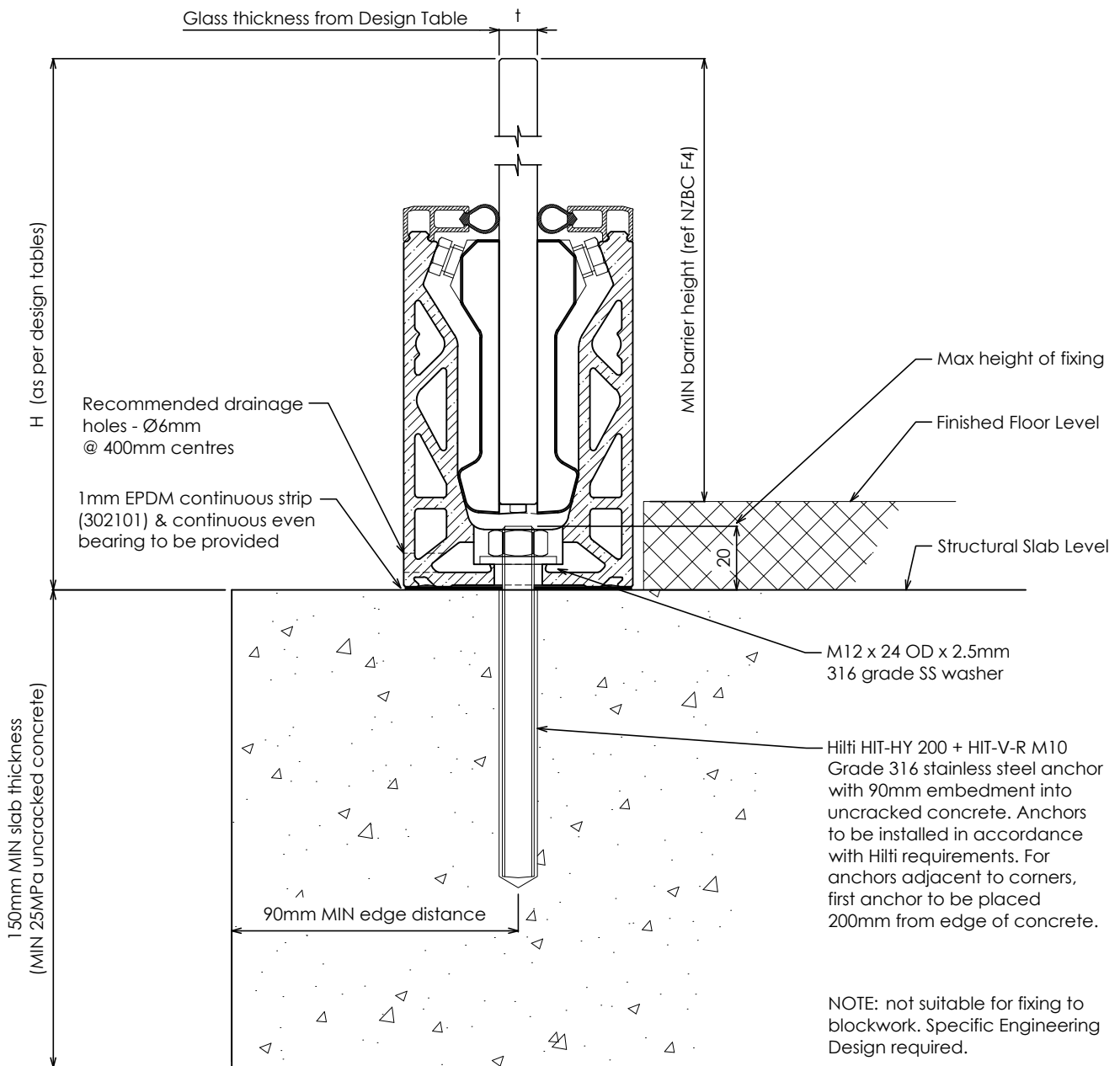

NOTE: not suitable for fixing to blockwork. Specific Engineering Design required.

Concrete building structure to be designed by building engineer to support loads as specified on PosiGlaze balustrade system design table.

**Notes:**

- 1) Capacity of structure is to be of sufficient strength to support loads M\* and T\* specified on PosiGlaze balustrade system design table. Structure capacity to be verified by building engineer prior to fixing balustrade.
- 2) Max loading to comply with AS/NZS 1170.1:2002 Minimum Imposed Actions for Barriers Occupancy, shown at top of drawing, for design in accordance with PosiGlaze balustrade system design table.
- 3) Penetration through a membrane must be completed in accordance with written instructions of the membrane manufacturer.
- 4) No substitution allowed - any variation from the details above and design tables will require specific design.

# PosiGlaze PG120B Balustrade System CONCRETE Fixing Detail

Drawing No.: PG120B/C/RA (M12)  
 Revision: R10  
 Fixing Type: PG120 with rod anchor (M12)  
 Occupancy: A, B, E, C3, C1/C2, D

Refer to PosiGlaze balustrade system design table for required glass thickness, fixing spacings and fixing loads according to AS/NZS 1170.1:2002 for the occupancies listed above.

**NOTES:** Refer to design tables and elevations for post failure requirements. Interlinking rail / clips not shown for clarity.  
 'H' refers to top of barrier.

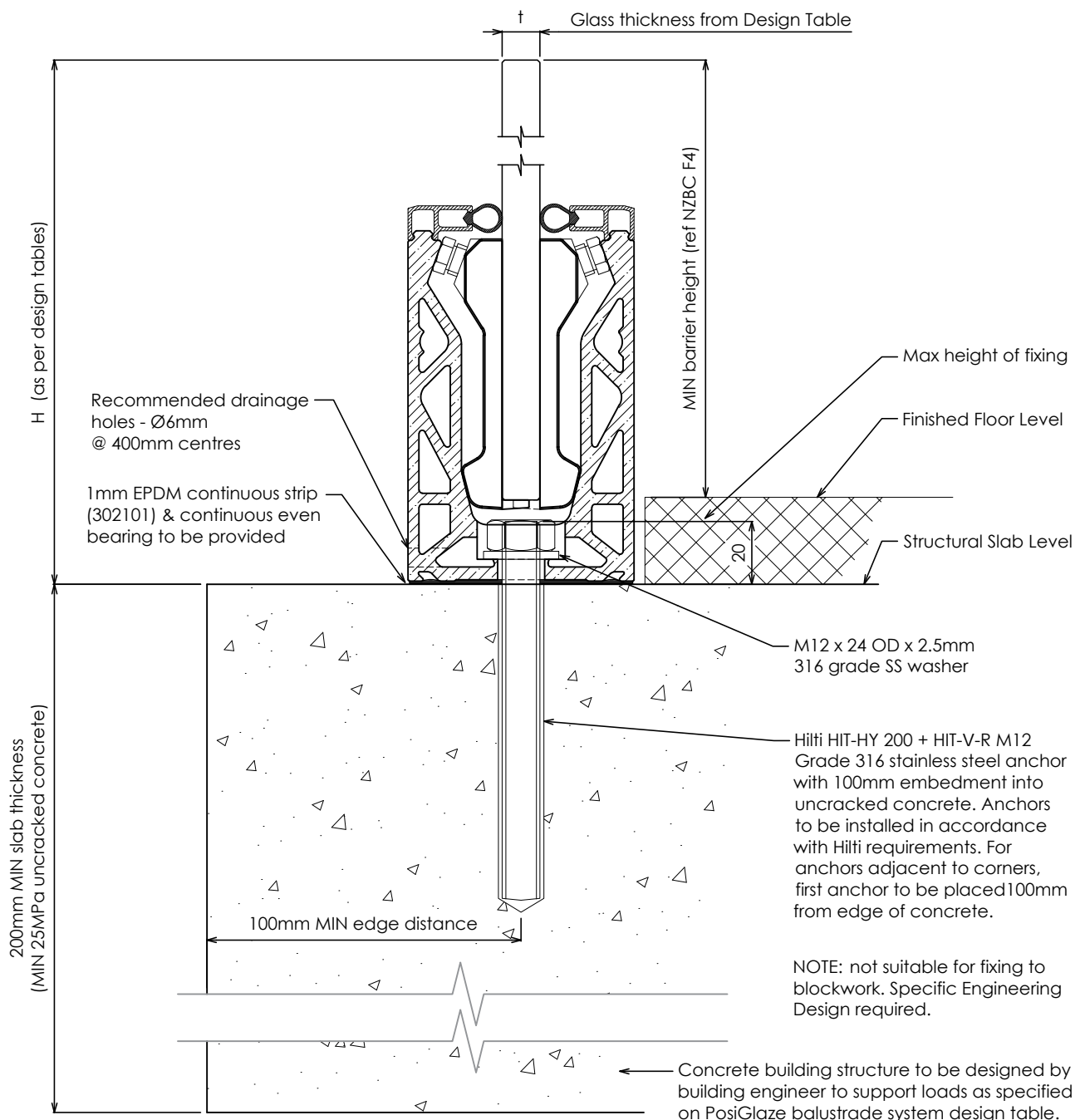

**Notes:**

- 1) Capacity of structure is to be of sufficient strength to support loads M\* and T\* specified on PosiGlaze balustrade system design table. Structure capacity to be verified by building engineer prior to fixing balustrade.
- 2) Max loading to comply with AS/NZS 1170.1:2002 Minimum Imposed Actions for Barriers Occupancy, shown at top of drawing, for design in accordance with PosiGlaze balustrade system design table.
- 3) Penetration through a membrane must be completed in accordance with written instructions of the membrane manufacturer.
- 4) No substitution allowed - any variation from the details above and design tables will require specific design.

# PosiGlaze PG120B Balustrade System STEEL Fixing Detail

Drawing No.: PG120B/S/BN  
 Revision: R10  
 Fixing Type: PG120 with bolt & nut  
 Occupancy: A, B, E, C3, C1/C2, D

Refer to PosiGlaze balustrade system design table for required glass thickness, fixing spacings and fixing loads according to AS/NZS 1170.1:2002 for the occupancies listed above.

**NOTES:** Refer to design tables and elevations for post failure requirements. Interlinking rail / clips not shown for clarity.  
 'H' refers to top of barrier.

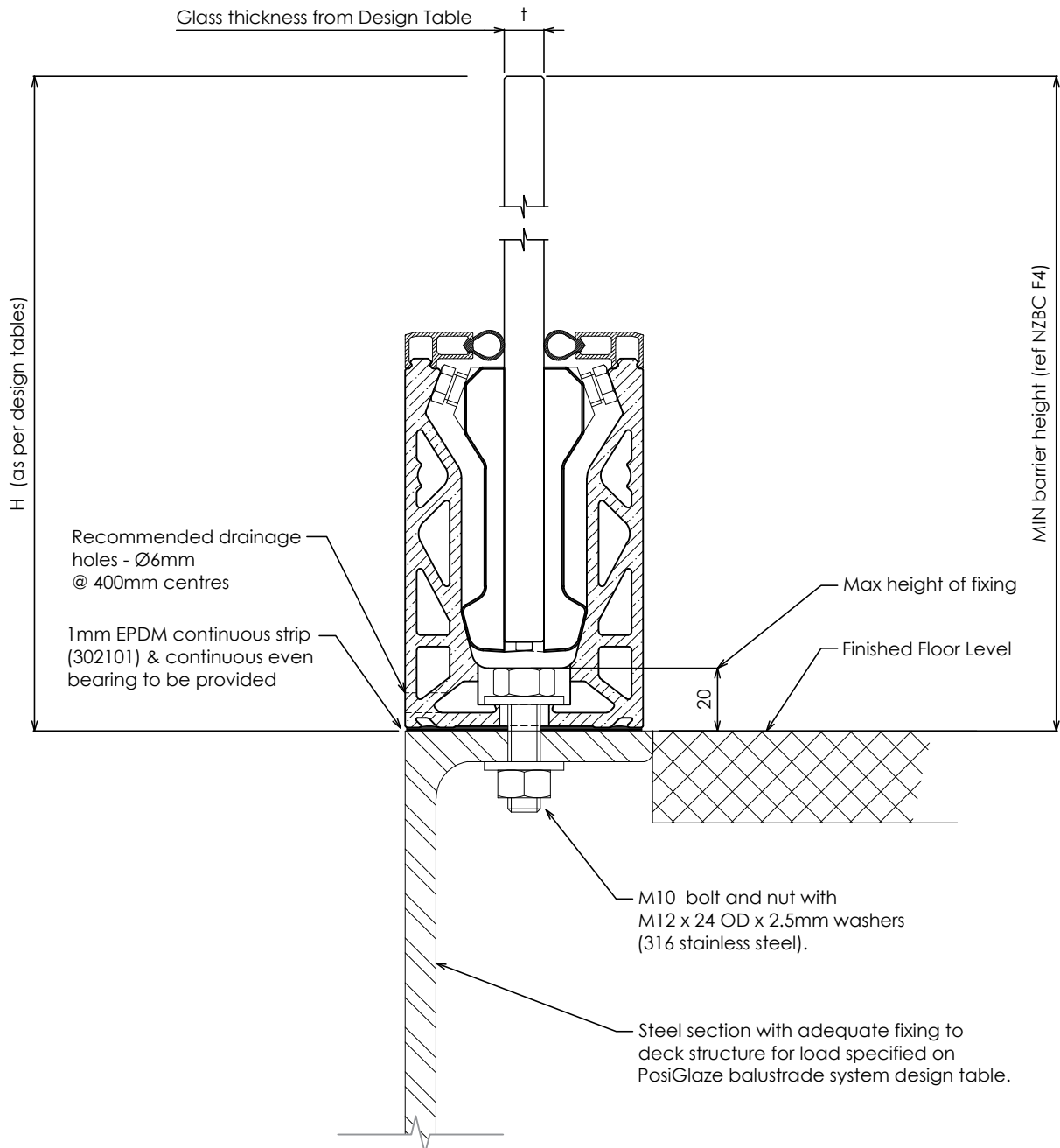

**Notes:**

- 1) Capacity of structure is to be of sufficient strength to support loads M\* and T\* specified on PosiGlaze balustrade system design table. Structure capacity to be verified by building engineer prior to fixing balustrade.
- 2) Max loading to comply with AS/NZS 1170.1:2002 Minimum Imposed Actions for Barriers Occupancy, shown at top of drawing, for design in accordance with PosiGlaze balustrade system design table.
- 3) Penetration through a membrane must be completed in accordance with written instructions of the membrane manufacturer.
- 4) For fixing to steel substrates, the installer shall ensure the bolts are tightened to a "snug-tight" level as defined in NZS3404.
- 5) No substitution allowed - any variation from the details above and design tables will require specific design.

# PosiGlaze PG120S & PG180S Balustrade System CONCRETE Fixing Detail

Drawing No.: PG120S-180S/C/RA(M10)

Revision: R10

Fixing Type: PG120S & PG180S  
with rod anchor (M10)

Occupancy: A, B, E, C3, C1/C2, D

Refer to PosiGlaze balustrade system design table for required glass thickness, fixing spacings and fixing loads according to AS/NZS 1170.1:2002 for the occupancies listed above.

**NOTES:** Refer to design tables and elevations for post failure requirements.  
Interlinking rail / clips not shown for clarity.  
'H' refers to top of barrier.

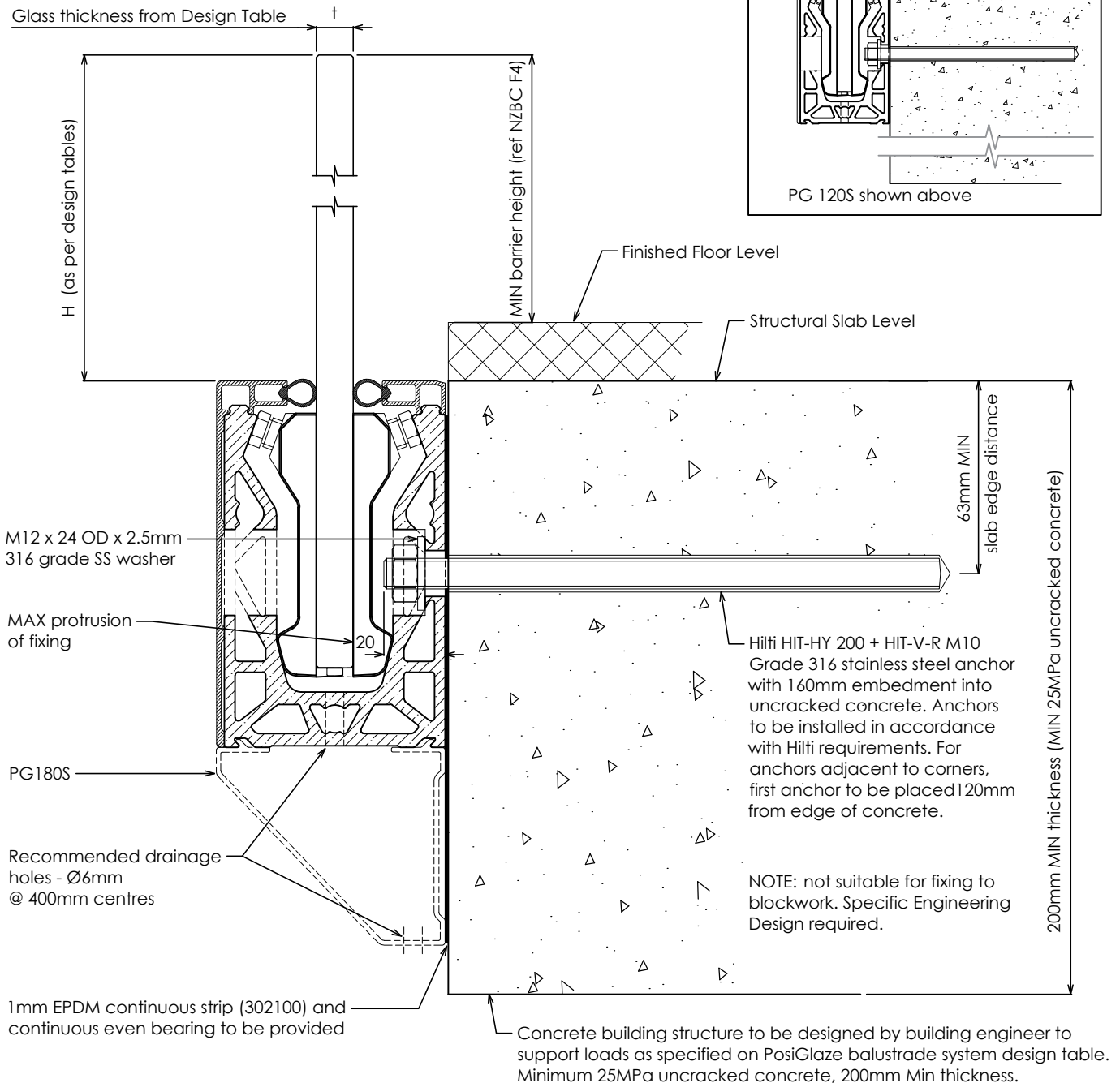
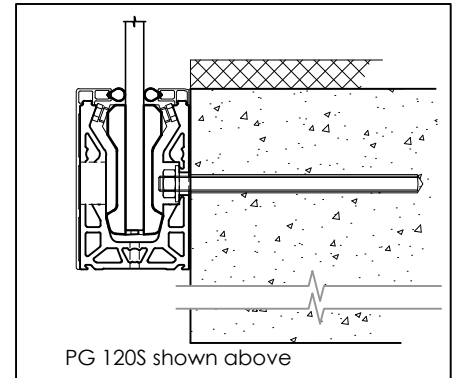

**Notes:**

- 1) Capacity of structure is to be of sufficient strength to support loads  $M^*$  and  $T^*$  specified on PosiGlaze balustrade system design table. Structure capacity to be verified by building engineer prior to fixing balustrade.
- 2) Max loading to comply with AS/NZS 1170.1:2002 Minimum Imposed Actions for Barriers Occupancy, shown at top of drawing, for design in accordance with PosiGlaze balustrade system design table.
- 3) Penetration through a membrane must be completed in accordance with written instructions of the membrane manufacturer.
- 4) No substitution allowed - any variation from the details above and design tables will require specific design.

# PosiGlaze PG120S & PG180S Balustrade System CONCRETE Fixing Detail

Drawing No.: PG120S-180S/C/RA(M12)

Revision: R10

Fixing Type: PG120S & PG180S  
with rod anchor (M12)

Occupancy: A, B, E, C3, C1/C2, D

Refer to PosiGlaze balustrade system design table for required glass thickness, fixing spacings and fixing loads according to AS/NZS 1170.1:2002 for the occupancies listed above.

**NOTES:** Refer to design tables and elevations for post failure requirements.  
Interlinking rail / clips not shown for clarity.  
'H' refers to top of barrier.

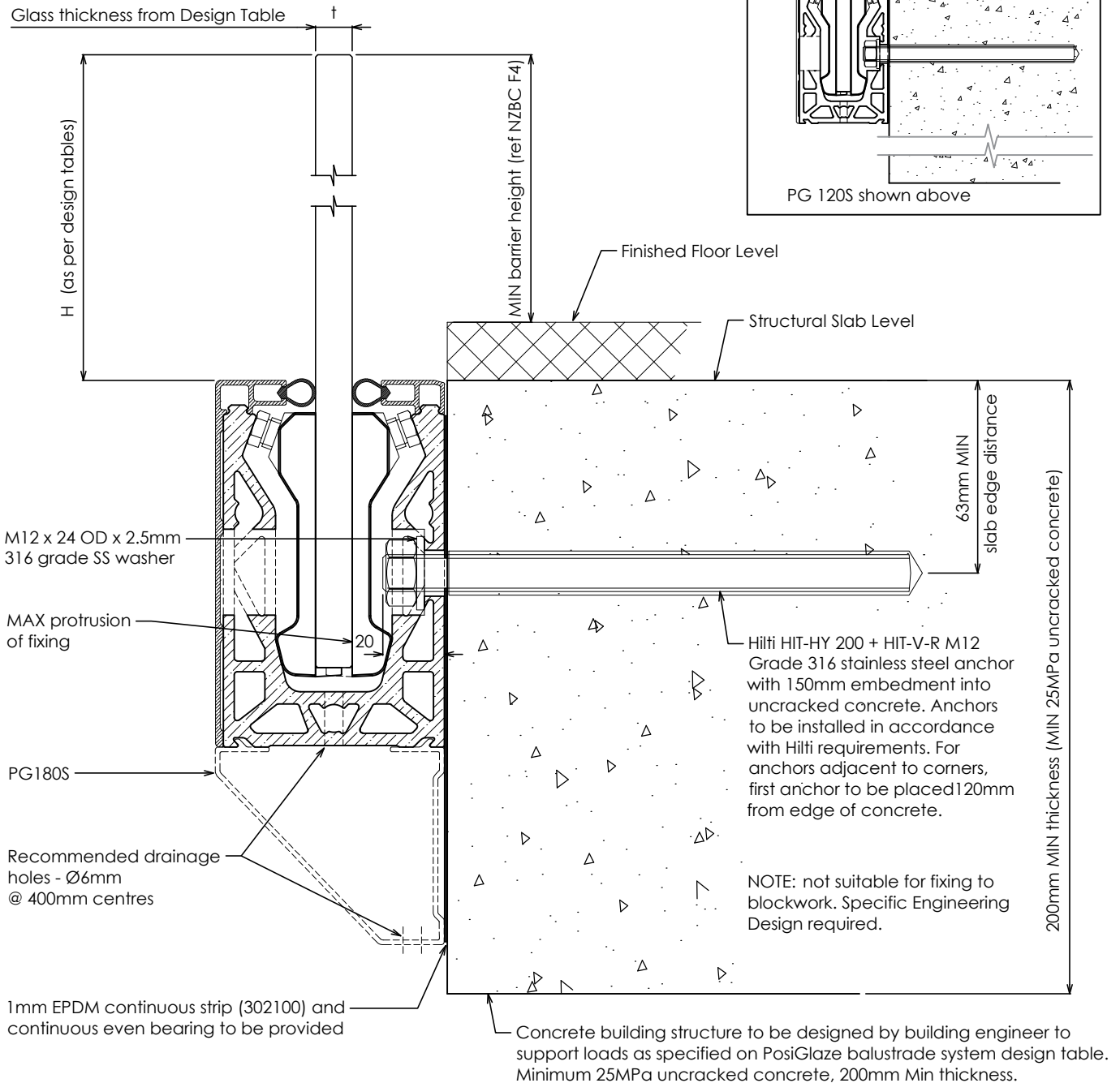
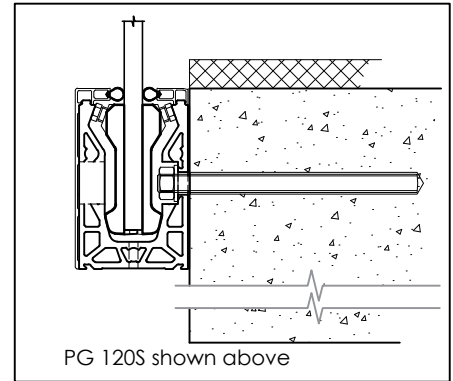

**Notes:**

- Capacity of structure is to be of sufficient strength to support loads  $M^*$  and  $T^*$  specified on PosiGlaze balustrade system design table. Structure capacity to be verified by building engineer prior to fixing balustrade.
- Max loading to comply with AS/NZS 1170.1:2002 Minimum Imposed Actions for Barriers Occupancy, shown at top of drawing, for design in accordance with PosiGlaze balustrade system design table.
- Penetration through a membrane must be completed in accordance with written instructions of the membrane manufacturer.
- No substitution allowed - any variation from the details above and design tables will require specific design.

# PosiGlaze PG120S & PG180S Balustrade System STEEL Fixing Detail

Drawing No.: PG120S-180S/S/BN  
 Revision: R10  
 Fixing Type: PG120S & PG180S  
 with bolt and nut  
 Occupancy: A, B, E, C3, C1/C2, D

Refer to PosiGlaze balustrade system design table for required glass thickness, fixing spacings and fixing loads according to AS/NZS 1170.1:2002 for the occupancies listed above.

**NOTES:** Refer to design tables and elevations for post failure requirements.  
 Interlinking rail / clips not shown for clarity.  
 'H' refers to top of barrier.

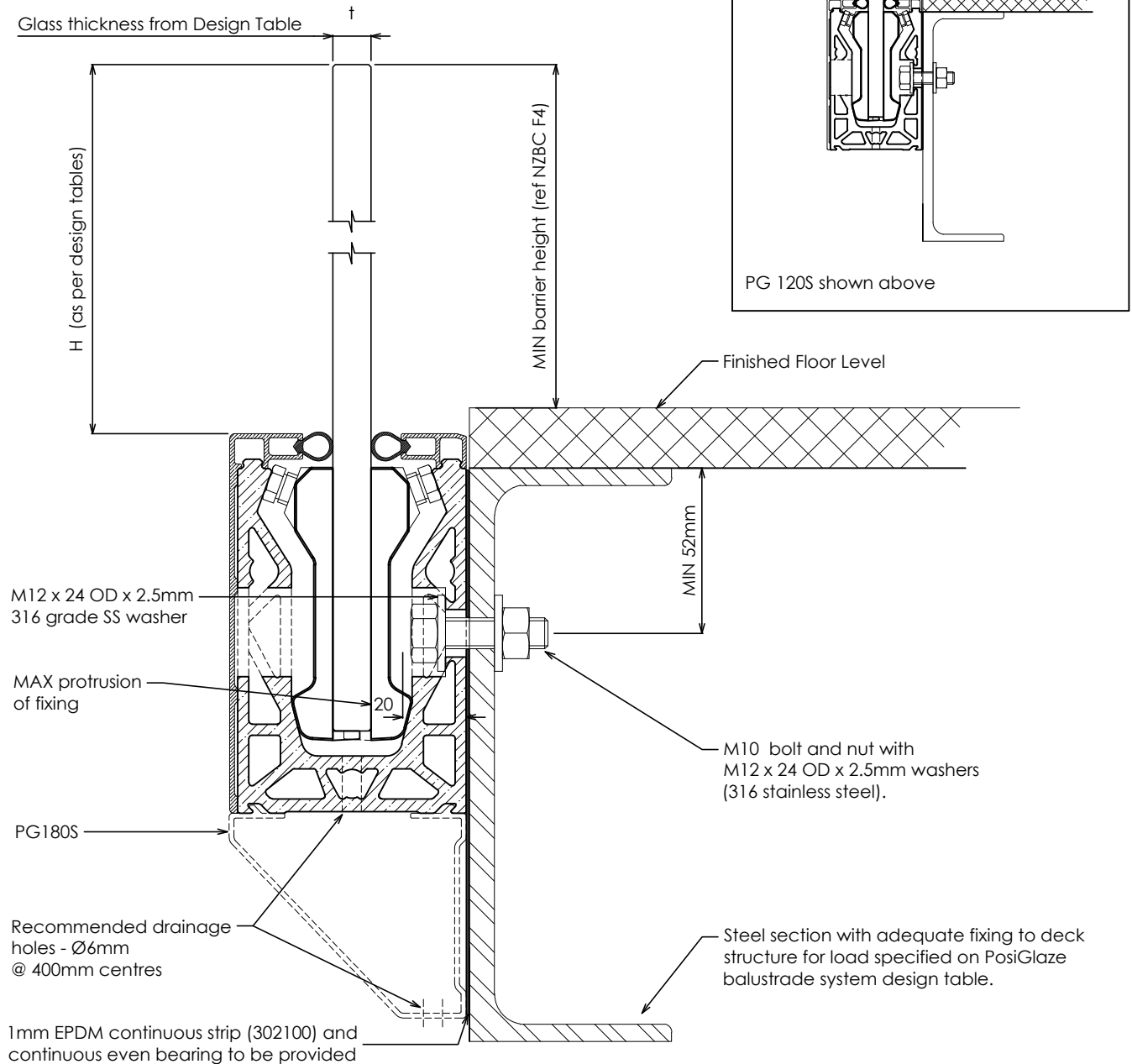

**Notes:**

- 1) Capacity of structure is to be of sufficient strength to support loads M\* and T\* specified on PosiGlaze balustrade system design table. Structure capacity to be verified by building engineer prior to fixing balustrade.
- 2) Max loading to comply with AS/NZS 1170.1:2002 Minimum Imposed Actions for Barriers Occupancy, shown at top of drawing, for design in accordance with PosiGlaze balustrade system design table.
- 3) Penetration through a membrane must be completed in accordance with written instructions of the membrane manufacturer.
- 4) For fixing to steel substrates, the installer shall ensure the bolts are tightened to a "snug-tight" level as defined in NZS3404.
- 5) No substitution allowed - any variation from the details above and design tables will require specific design.

# PosiGlaze PG120S & PG180S Balustrade System TIMBER Fixing Detail

Drawing No.: PG120S-180S/T/BN  
 Revision: R10  
 Fixing Type: PG120S & PG180S  
 with bolt and nut  
 Occupancy: A, B, E, C3  
**NOT SUITABLE FOR OCCUPANCY C1/C2, D OR C5**

Refer to PosiGlaze balustrade system design table for required glass thickness, fixing spacings and fixing loads according to AS/NZS 1170.1:2002 for the occupancies listed above.

**NOTES:** Refer to design tables and elevations for post failure requirements.  
 Interlinking rail / clips not shown for clarity.  
 'H' refers to top of barrier.

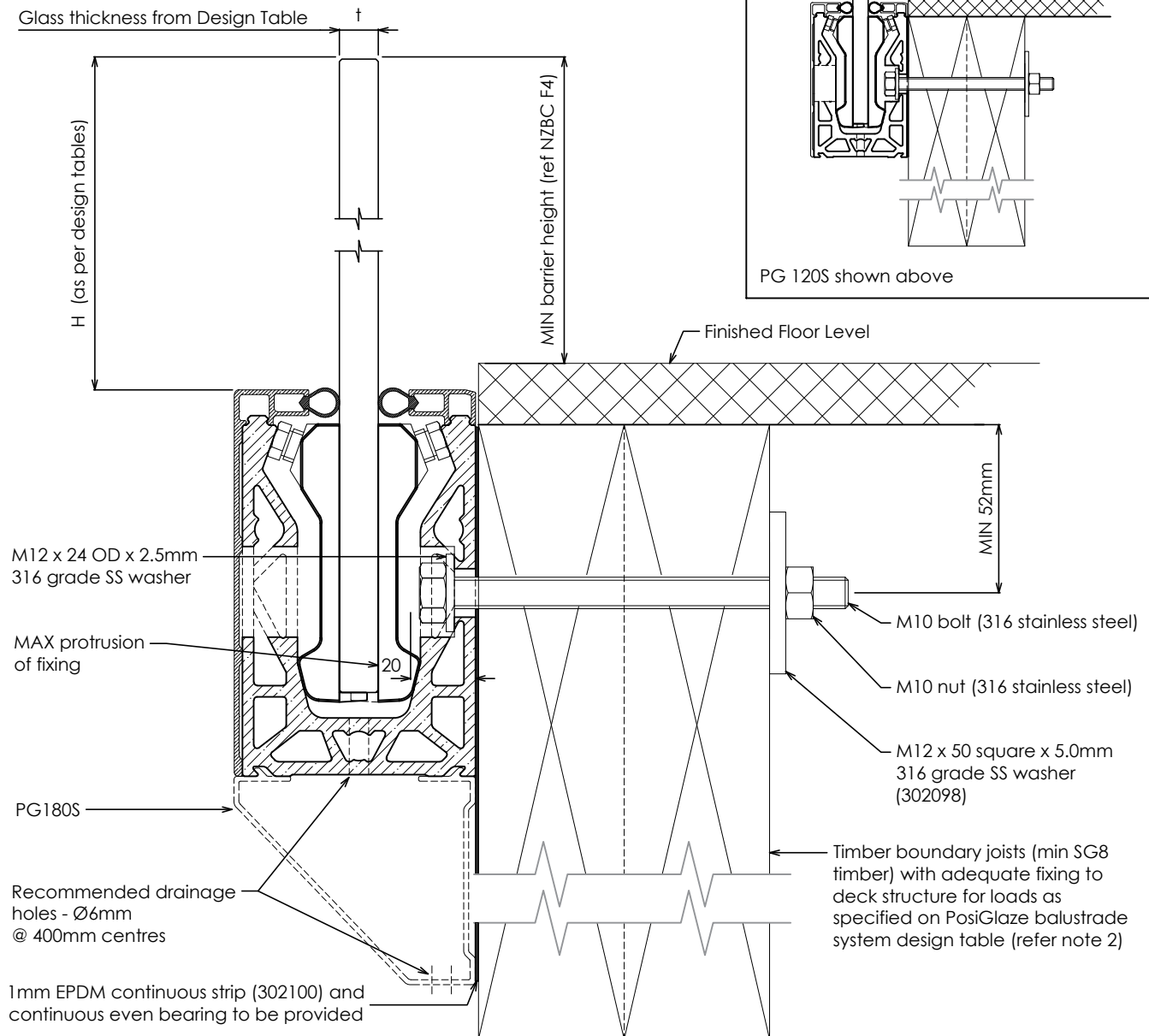

**NOTES:**

- 1) Capacity of structure is to be of sufficient strength to support loads M\* and T\* specified on PosiGlaze balustrade system design table. Structure capacity to be verified by building engineer where applicable or checked to NZS3604 requirements prior to fixing balustrade.
- 2) Timber decks designed to NZS 3604:2011 guidelines will meet loading requirement, **except for decks including cantilever floor joists where specific design is required.**
- 3) Max loading to comply with AS/NZS 1170.1:2002 Minimum Imposed Actions for Barriers Occupancy, shown at top of drawing, for design in accordance with PosiGlaze balustrade system design table.
- 4) Penetration through a membrane must be completed in accordance with written instructions of the membrane manufacturer.
- 5) For fixing to timber substrates, the installer shall ensure that the bolt / coach screw is sufficiently tightened to reduce movement of the bolt head and washer. Care should be taken not to over tighten the fixings that would cause crushing of the timber or compromise the thread leading to anchor pull-out.
- 6) No substitution allowed - any variation from the details above and design tables will require specific design.



# PosiGlaze PG120S & PG180S Balustrade System TIMBER Fixing Detail

Drawing No.: PG120S-180S/T/CS  
 Revision: R10  
 Fixing Type: PG120S & PG180S  
 with coach screw  
 Occupancy: A, B, E, C3  
**NOT SUITABLE FOR OCCUPANCY C1/C2, D OR C5**

Refer to PosiGlaze balustrade system design table for required glass thickness, fixing spacings and fixing loads according to AS/NZS 1170.1:2002 for the occupancies listed above.

**NOTES:** Refer to design tables and elevations for post failure requirements.  
 Interlinking rail / clips not shown for clarity.  
 'H' refers to top of barrier.

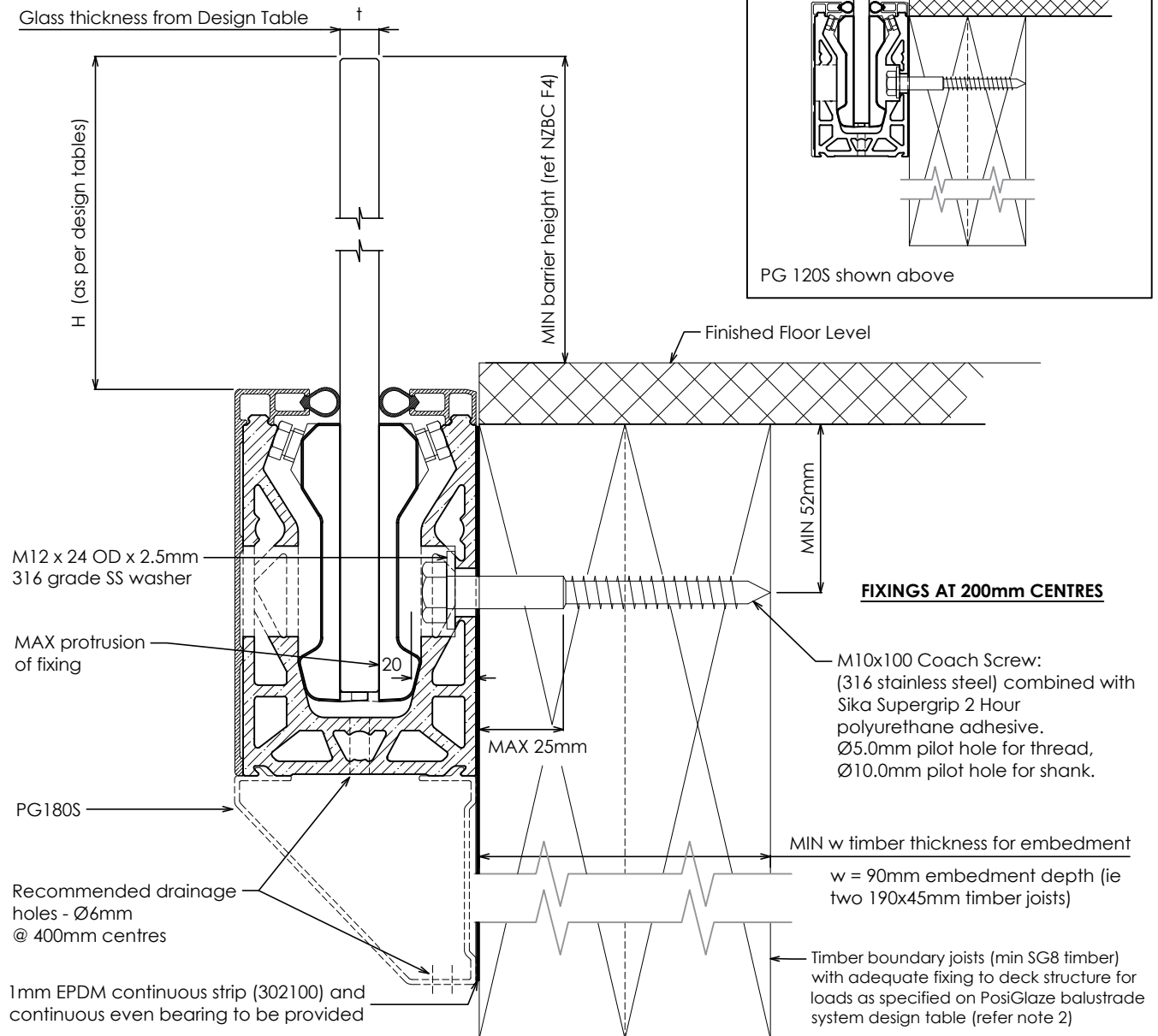

**NOTES:**

- 1) Capacity of structure is to be of sufficient strength to support loads  $M^*$  and  $T^*$  specified on PosiGlaze balustrade system design table. Structure capacity to be verified by building engineer where applicable or checked to NZS3604 requirements prior to fixing balustrade.
- 2) Timber decks designed to NZS 3604:2011 guidelines will meet loading requirement, **except for decks including cantilever floor joists where specific design is required.**
- 3) Max loading to comply with AS/NZS 1170.1:2002 Minimum Imposed Actions for Barriers Occupancy, shown at top of drawing, for design in accordance with PosiGlaze balustrade system design table.
- 4) Penetration through a membrane must be completed in accordance with written instructions of the membrane manufacturer.
- 5) For fixing to timber substrates, the installer shall ensure that the bolt / coach screw is sufficiently tightened to reduce movement of the bolt head and washer. Care should be taken not to over tighten the fixings that would cause crushing of the timber or compromise the thread leading to anchor pull-out.
- 6) No substitution allowed - any variation from the details above and design tables will require specific design.

**POSIGLAZE ELEVATION (DRAWING 01)**  
**SAFELITE STF GLASS**

**POSIGLAZE SYSTEM**  
**SAFELITE STF 13.52mm**

**PANEL WIDTH NOTES:**

Balustrade stiffener brackets or interlinking rail required for panels <1700mm.  
Minimum panel width where two or more panels are in a straight line = 1000mm.  
Minimum width for short return panel = 200mm.

**Residential & Commercial**  
**Occupancy types A, A other, C3, B and E.**

GLASS & FIXING SPECIFICATIONS:  
Refer to design table for maximum glass height, maximum fixing spacing and design loads to structure.

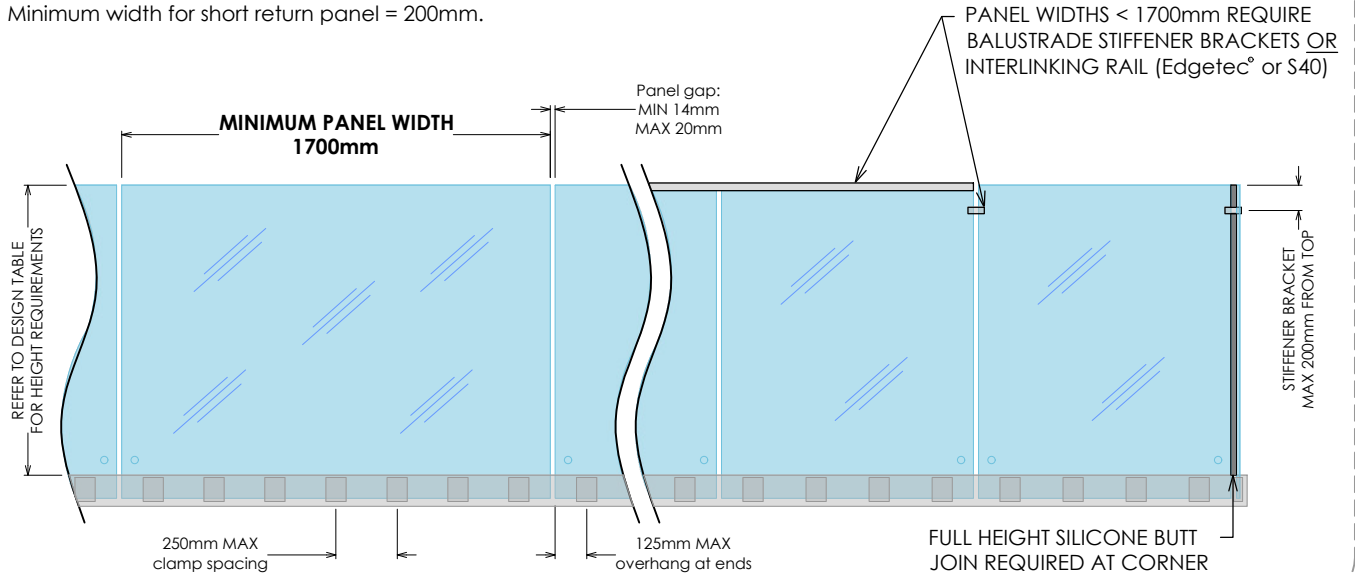

**POSIGLAZE SYSTEM**  
**SAFELITE STF 17.52mm**  
**SAFELITE STF 21.52mm**

**PANEL WIDTH NOTES:**

Balustrade stiffener brackets or interlinking rail required for panels <1100mm.  
Minimum panel width where two or more panels are in a straight line = 1000mm.  
Minimum width for short return panel = 200mm.

**17.52mm - Residential & Commercial**  
**Occupancy types A, A other, C3, B and E.**

**21.52mm - Commercial**  
**Occupancy types C1, C2 and D.**

GLASS & FIXING SPECIFICATIONS:  
Refer to design table for maximum glass height, maximum fixing spacing and design loads to structure.

**FOR OCCUPANCIES A, A other, C3, B & E ONLY:**  
PANEL WIDTHS < 1100mm REQUIRE BALUSTRADE STIFFENER BRACKETS OR INTERLINKING RAIL (Edgetec or S40).  
**FOR OCCUPANCIES C1, C2 & D:**  
1100mm MINIMUM WIDTH APPLIES.

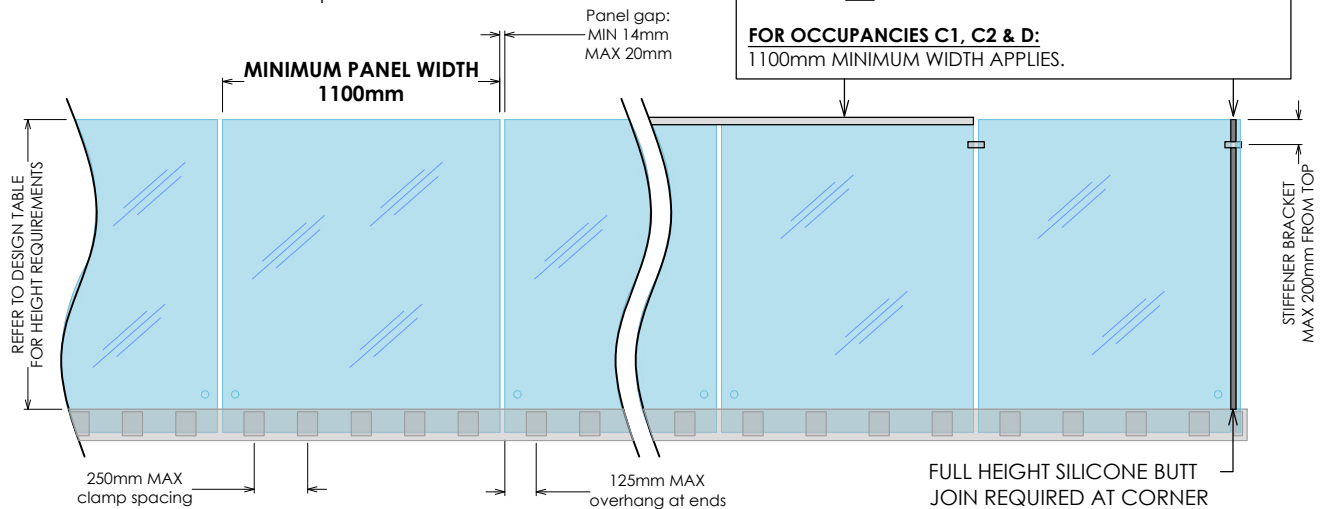

**IMPORTANT NOTE:** The substructure to which the balustrade is to be attached must be designed by a structural engineer to resist the relevant balustrade actions as per B1/VM1.

**POSIGLAZE ELEVATION (DRAWING 02)**  
**SAFELITE EVA GLASS**

**POSIGLAZE GLASS CLAMP**  
SAFELITE EVA 15.2mm  
SAFELITE EVA 17.2mm

**PANEL WIDTH NOTES:**

Minimum panel width where two or more panels are in a straight line = 1000mm.  
Minimum width for short return panel = 200mm.

**Residential & Commercial**  
**Occupancy types A, A other, C3, B and E.**

GLASS & FIXING SPECIFICATIONS:  
Refer to design table for maximum glass height, maximum fixing spacing and design loads to structure.

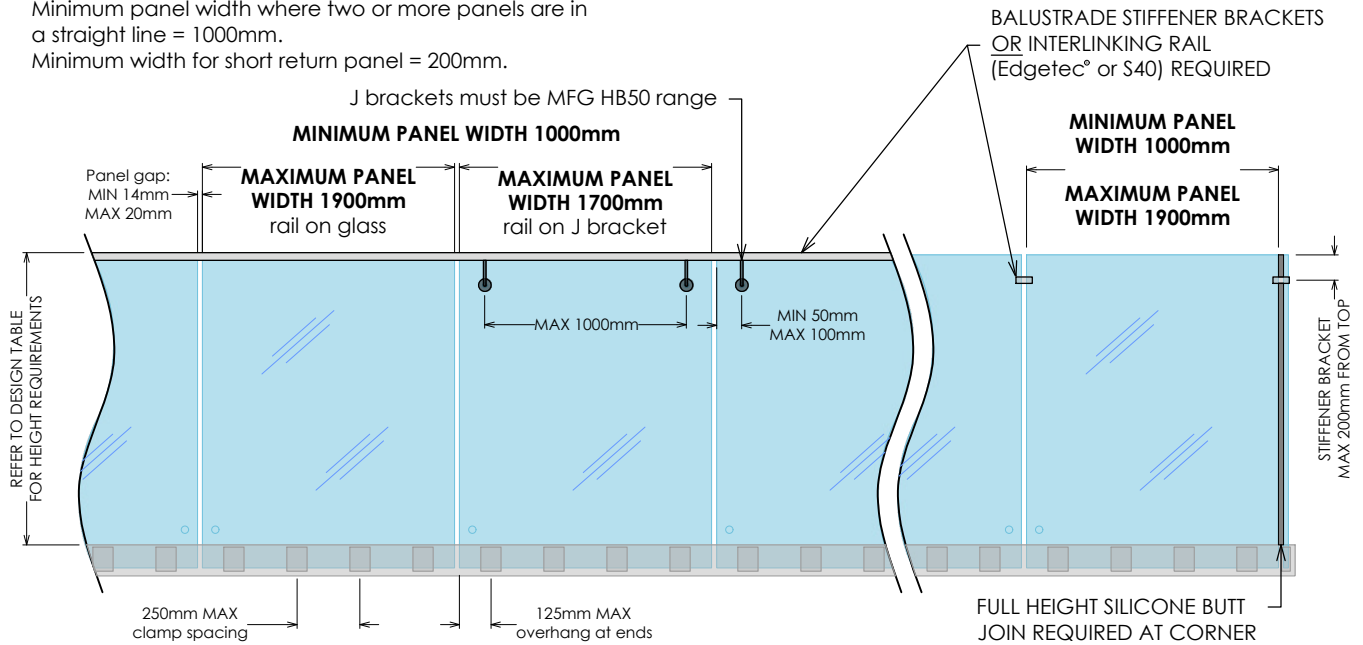

**POSIGLAZE SYSTEM**  
SAFELITE EVA 19.2mm

**PANEL WIDTH NOTES:**

Minimum panel width where two or more panels are in a straight line = 1000mm.  
Minimum width for short return panel = 200mm.

**Residential & Commercial**  
**Occupancy types A, A other, C3, B and E.**

GLASS & FIXING SPECIFICATIONS:  
Refer to design table for maximum glass height, maximum fixing spacing and design loads to structure.

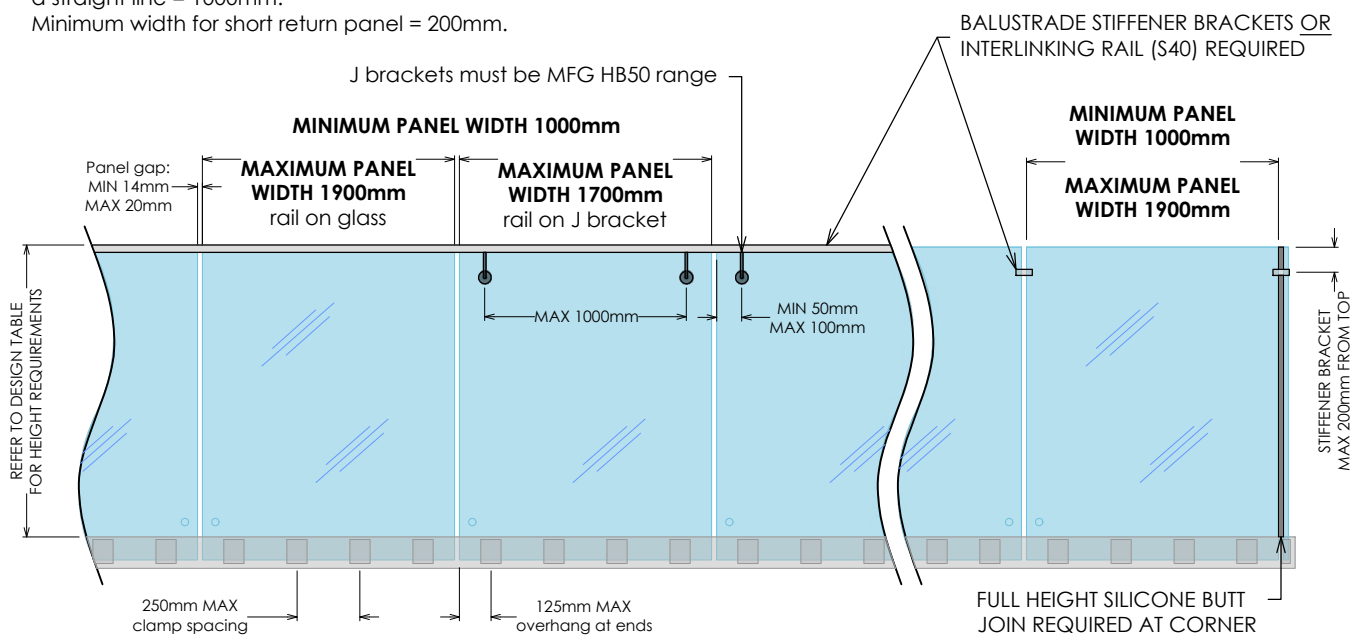

**IMPORTANT NOTE:** The substructure to which the balustrade is to be attached must be designed by a structural engineer to resist the relevant balustrade actions as per B1/VM1.

**POSIGLAZE ELEVATION (DRAWING 03)  
TEMPAFLOAT GLASS**

**POSIGLAZE SYSTEM  
TEMPAFLOAT 12mm**

**PANEL WIDTH NOTES:**

Minimum panel width where two or more panels are in a straight line = 1000mm.  
Minimum width for short return panel = 200mm.

**Residential & Commercial  
Occupancy types A, A other, C3, B and E.**

GLASS & FIXING SPECIFICATIONS:  
Refer to design table for maximum glass height, maximum fixing spacing and design loads to structure.

**INTERLINKING RAIL REQUIRED:**

- S25 (on glass only, MAX 1700mm panels)
- S40 & Edgetec<sup>®</sup> (on MFG HB50 J brackets, MAX 1700mm panels)
- S40 & Edgetec<sup>®</sup> (on glass, MAX 1900mm panels)

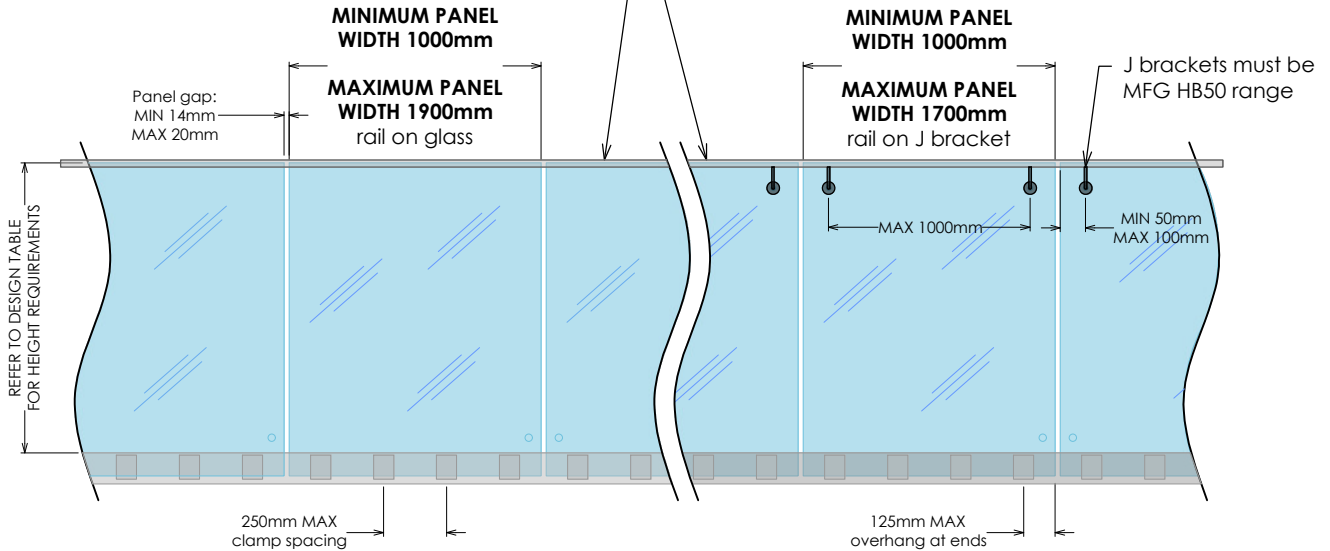

**POSIGLAZE SYSTEM  
TEMPAFLOAT 15mm**

**PANEL WIDTH NOTES:**

Minimum panel width where two or more panels are in a straight line = 1000mm.  
Minimum width for short return panel = 200mm.

**Residential & Commercial  
Occupancy types A, A other, C3, B and E.**

GLASS & FIXING SPECIFICATIONS:  
Refer to design table for maximum glass height, maximum fixing spacing and design loads to structure.

**INTERLINKING RAIL (S40 or Edgetec<sup>®</sup>) REQUIRED**

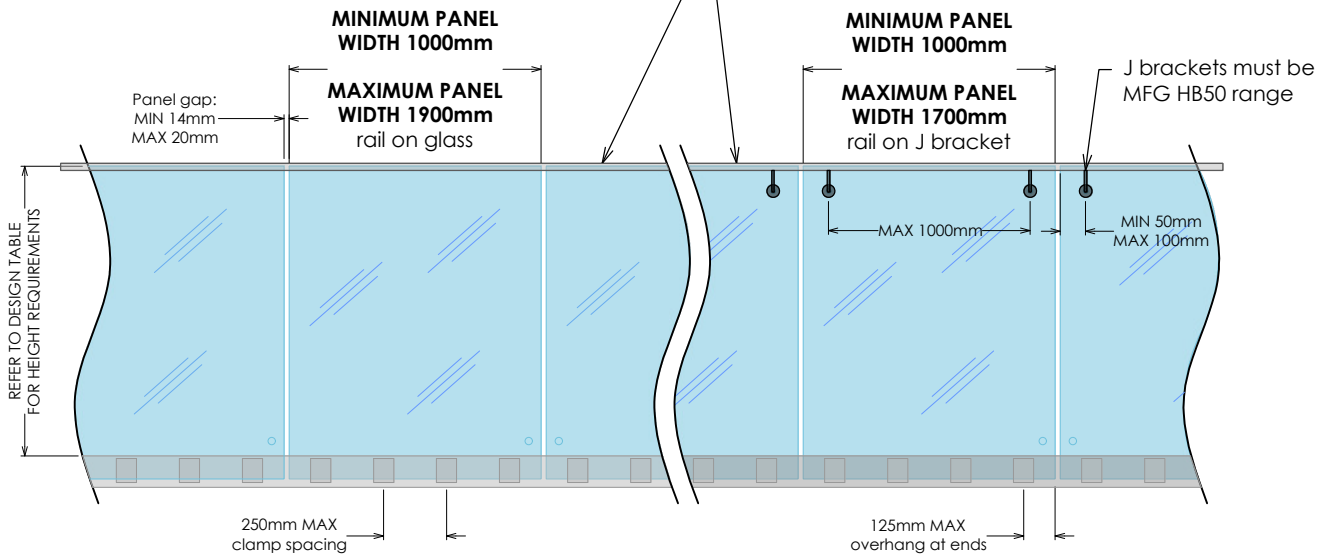

**IMPORTANT NOTE:** The substructure to which the balustrade is to be attached must be designed by a structural engineer to resist the relevant balustrade actions as per B1/VM1.

## POSIGLAZE ELEVATION (DRAWING 04) POOL FENCE

### POSIGLAZE SYSTEM POOL FENCE ONLY (BASE FIX)

APPLIES TO FREE STANDING POOL FENCES NOT PROTECTING A FALL OF > 1000mm.

As of Jan 2017, complies with Building Code clause F9 & section 162C of the building Act.

**GLASS & FIXING SPECIFICATIONS:**  
Refer to design table for maximum glass height, maximum fixing spacing and design loads to structure.

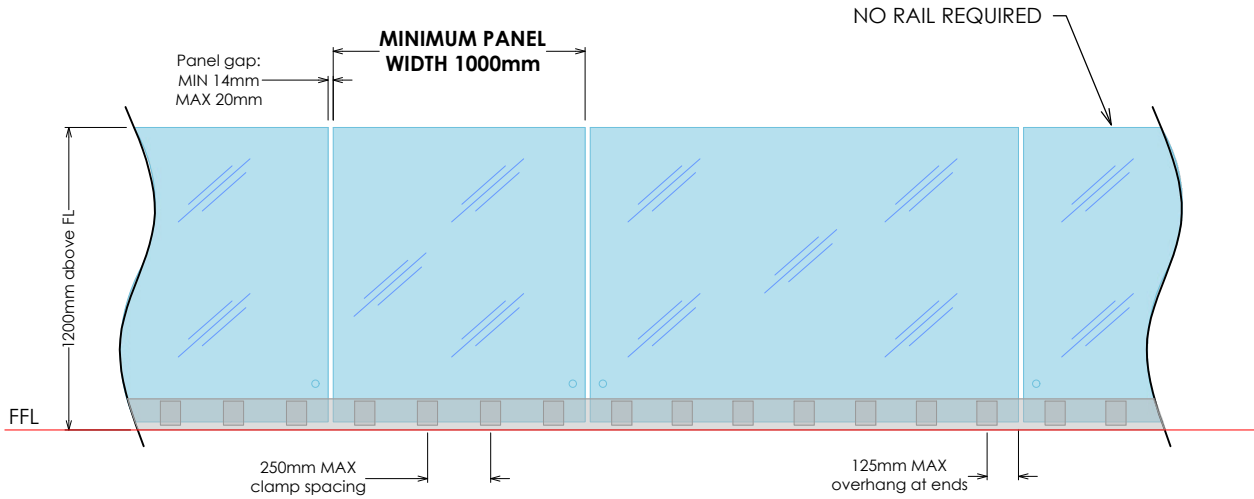

### POSIGLAZE SYSTEM POOL FENCE ONLY (SIDE FIX)

APPLIES TO FREE STANDING POOL FENCES NOT PROTECTING A FALL OF > 1000mm.

As of Jan 2017, complies with Building Code clause F9 & section 162C of the building Act.

**GLASS & FIXING SPECIFICATIONS:**  
Refer to design table for maximum glass height, maximum fixing spacing and design loads to structure.

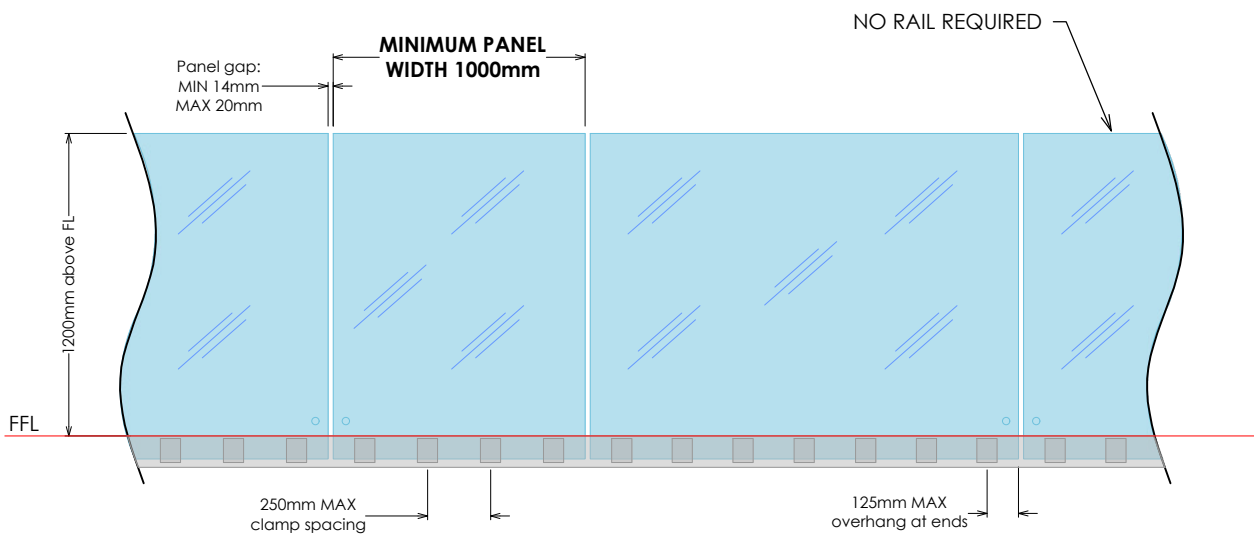

**IMPORTANT NOTE:** The substructure to which the balustrade is to be attached must be designed by a structural engineer to resist the relevant balustrade actions as per B1/VM1.

## POSIGLAZE ELEVATION (DRAWING 05) STAIR BALUSTRADE

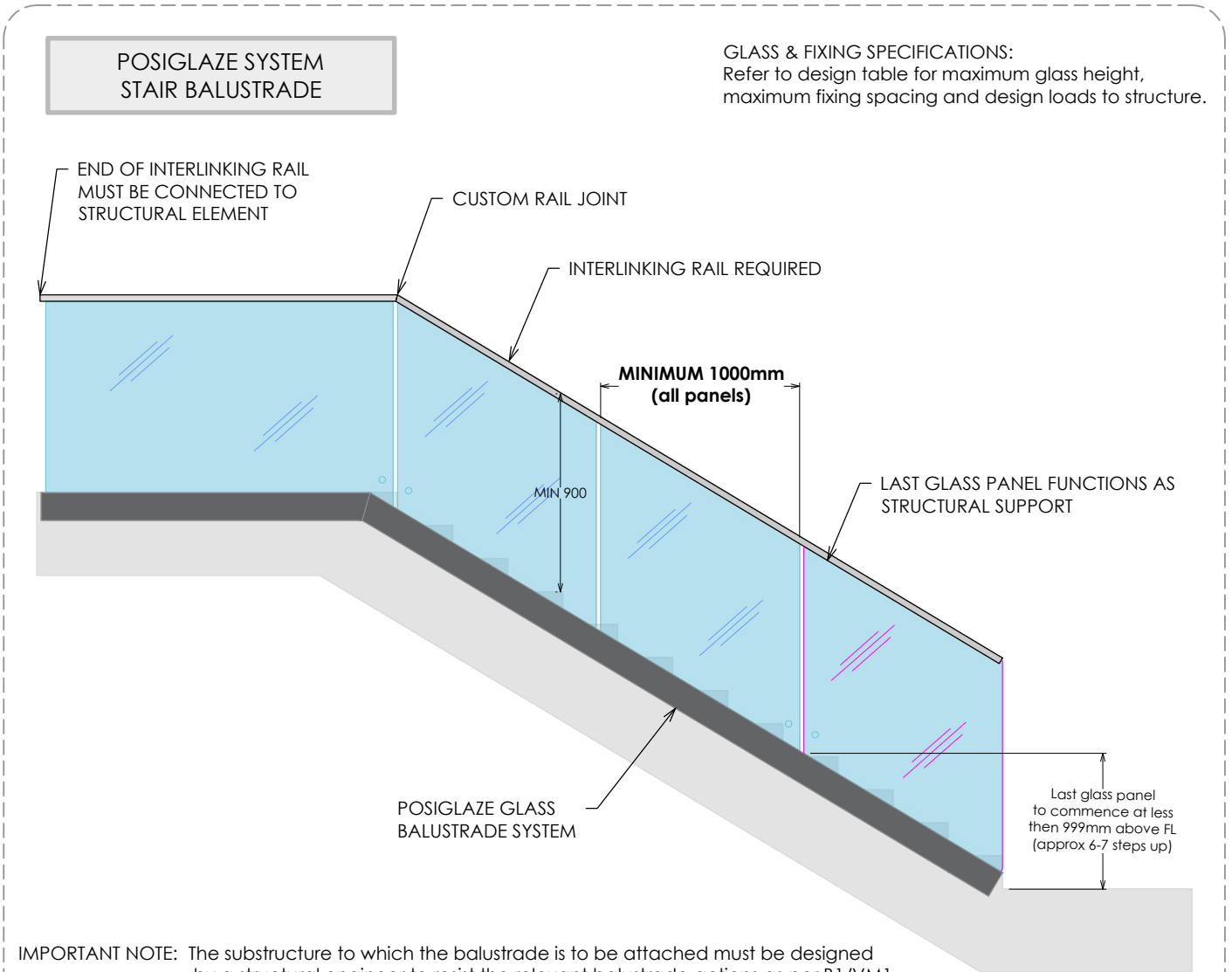

**IMPORTANT NOTE:** The substructure to which the balustrade is to be attached must be designed by a structural engineer to resist the relevant balustrade actions as per B1/VM1.

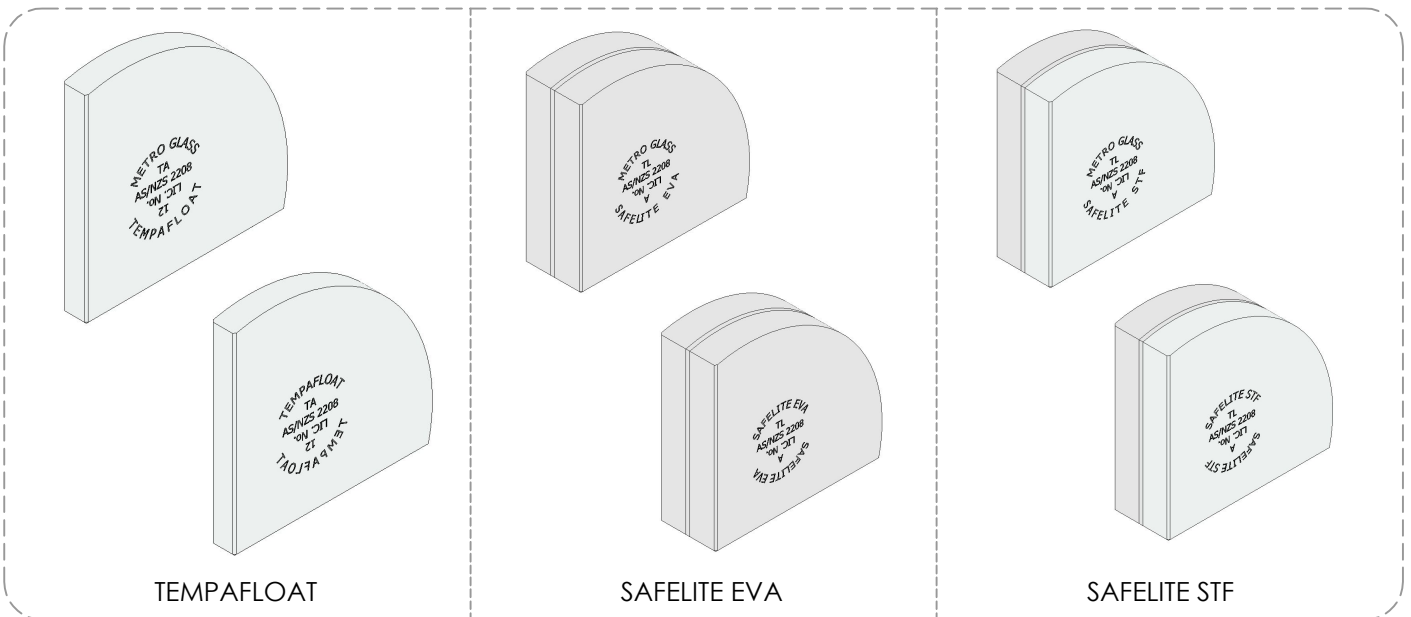

**POSIGLAZE RAIL & BRACKETS (DRAWING 06)**  
**BALUSTRADE STIFFENER BRACKETS**

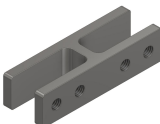
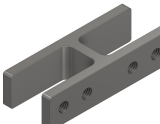
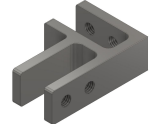
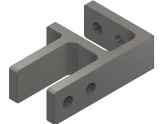
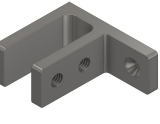
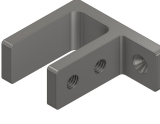
Product	Code	Description	Product	Code	Description
	300149 (180° bracket)	Suit glass from 13.5 - 15.5mm. Stiffener bracket - No holes required. 180° glass to glass. 70mm overall x 25mm. Duplex 2205. Stainless Steel Satin finish.		300150 (180° bracket)	Suit glass from 17.52 - 21.52mm. Stiffener bracket - No holes required. 180° glass to glass. 103mm overall x 25mm. Duplex 2205. Stainless Steel Satin finish.
	300151 (90° bracket)	Suit glass from 13.5 - 15.5mm. Stiffener bracket - No holes required. 90° glass to glass. 75mm x 50mm x 25mm. Duplex 2205. Stainless Steel Satin finish.		300152 (90° bracket)	Suit glass from 17.52 - 21.52mm. Stiffener bracket - No holes required. 90° glass to glass. 88mm x 55mm x 25mm. Duplex 2205. Stainless Steel Satin finish.
	300153 (wall bracket)	Suit glass from 13.5 - 15.5mm. Stiffener bracket - No holes required. 90° glass to wall. 65mm x 55mm x 25mm. Duplex 2205. Stainless Steel Satin finish.		300154 (wall bracket)	Suit glass from 17.52 - 21.52mm. Stiffener bracket - No holes required. 90° glass to wall. 65mm x 55mm x 25mm. Duplex 2205. Stainless Steel Satin finish.

All brackets are supplied with a selection of gaskets to suit glass thickness and includes stainless steel clamping plates.

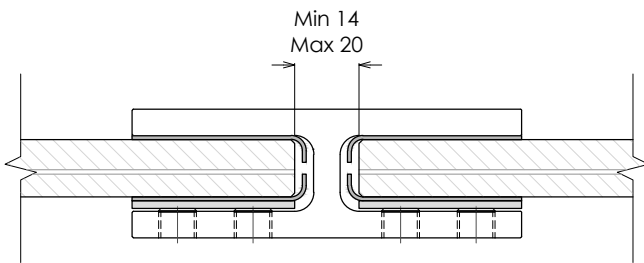

**13.5-15.5mm GLASS - STRAIGHT BRACKET**  
**300149**

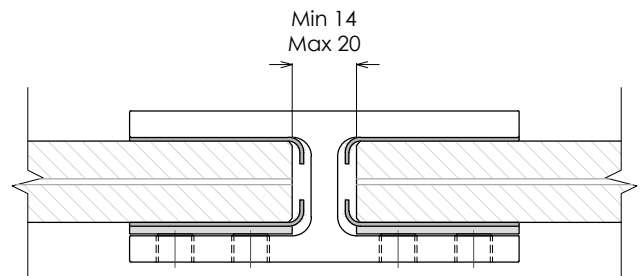

**17.52 - 21.52mm GLASS - STRAIGHT BRACKET**  
**300150**

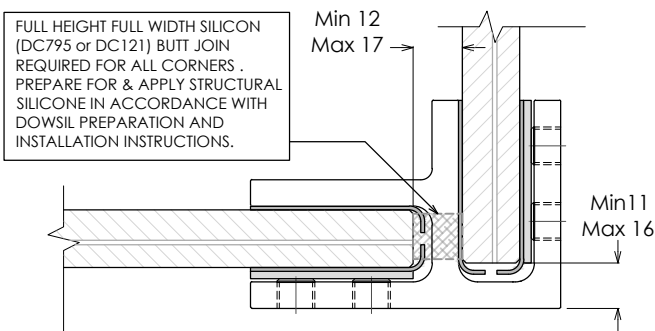

**13.5-15.5mm GLASS - CORNER BRACKET**  
**300151**

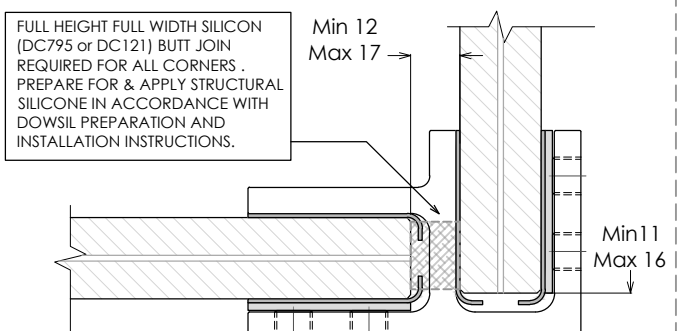

**17.52 - 21.52mm GLASS - CORNER BRACKET**  
**300152**

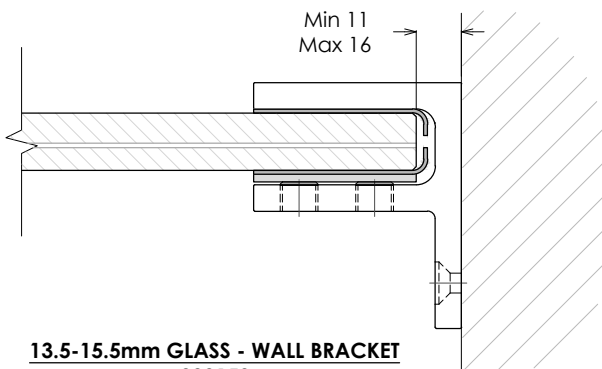

**13.5-15.5mm GLASS - WALL BRACKET**  
**300153**

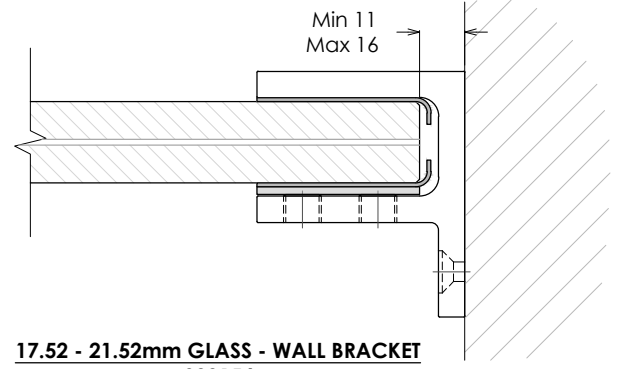

**17.52 - 21.52mm GLASS - WALL BRACKET**  
**300154**

**POSIGLAZE RAIL & BRACKETS (DRAWING 07)**  
**EDGEtec<sup>®</sup> RAIL conforming to NZS 4223.3.2016 and Building Code Clause B1/AS1 CI 7.3.1**

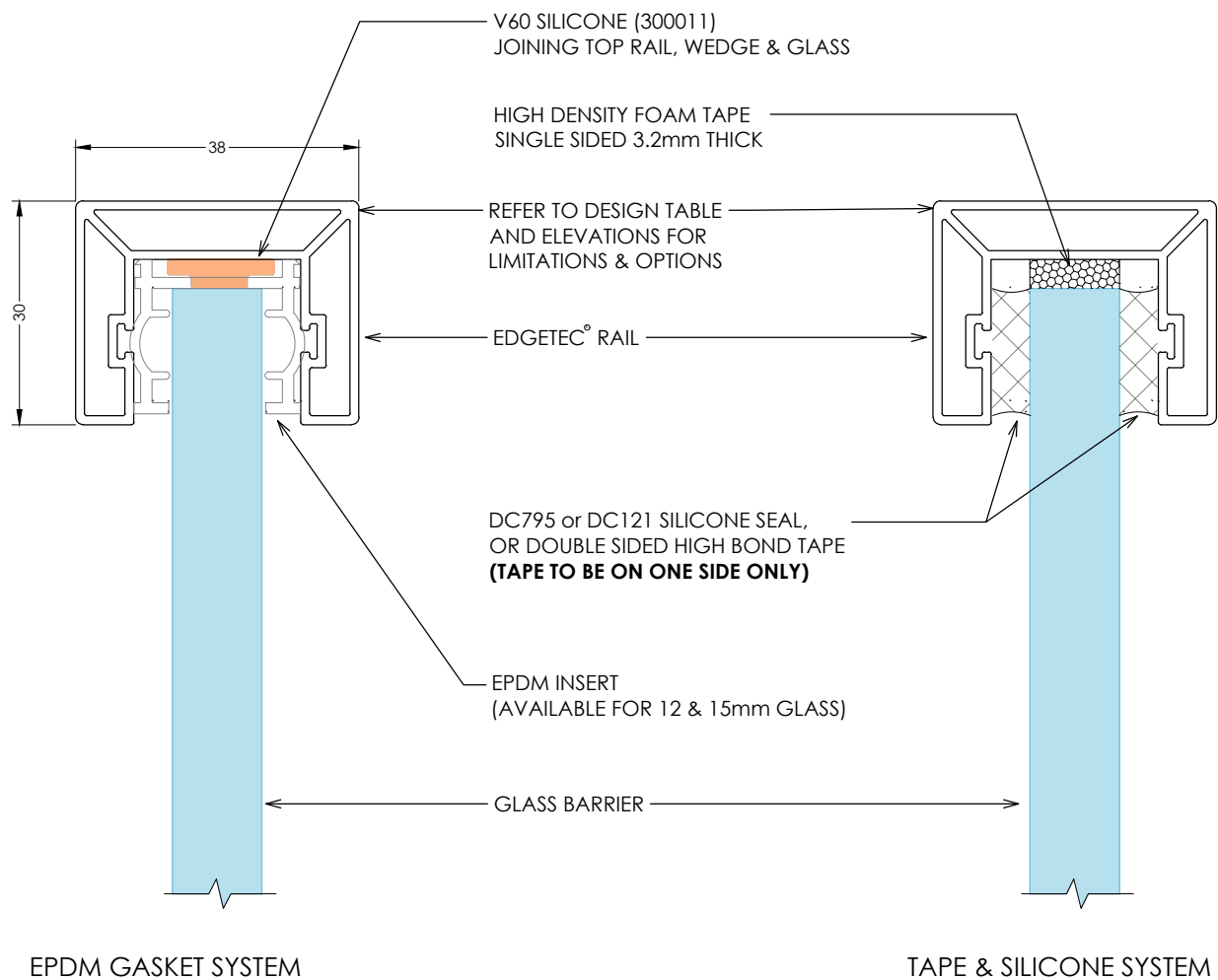

**EDGEtec<sup>®</sup> RAIL**

**INSTALLATION NOTES:**

1. CUT SHORT LENGTHS OF GASKET (nom 50mm) AND PLACE AT APPROXIMATELY 700mm CENTRES.
2. CUT / ADJUST INTERLINKING RAIL TO CORRECT DIMENSIONS AND TEST IN POSITION.
3. REMOVE ALL PARTS FROM GLASS BARRIER AND INSTALL FULL CUT LENGTHS OF GASKET TO TOP EDGE OF GLASS BARRIER.
4. ASSEMBLE TOP RAIL, JOINERS AND SUITABLE END PLATES.
5. PLACE BLOBS OF V60 SILICONE IN EVERY GASKET HOLE.
6. PLACE TOP RAIL EXTRUSION, JOINERS AND END PLATES IN POSITION ON GLASS BARRIER, CLIPPING FIRMLY TO GASKET.
7. TAPE ASSEMBLED COMPONENTS DOWN TO GLASS BARRIER AND WAIT 24hrs TO FULLY BOND.
8. CLEAN UP ANY EXCESS SILICONE.

**NOTE:** RAIL ENDS MUST BE ATTACHED TO STRUCTURE OR STRUCTURAL POST.  
 EXTRUSION JOINS MUST HAVE A SUITABLE JOINER PLATE



**POSIGLAZE RAIL & BRACKETS (DRAWING 08)**

**EDGETEC® RAIL conforming to NZS 4223.3.2016 and Building Code Clause B1/AS1 CI 7.3.1**

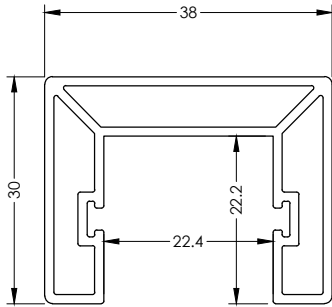

Edgetec® 220 Rail for 12mm & 15mm Glass  
 Full Length (5800mm) 300729  
 Half Length (2900mm) 300726  
 38x30mm

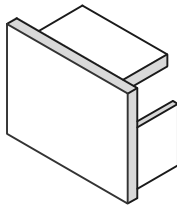

Edgetec® 220 Rail  
 End Cap (300494)  
 38x30mm

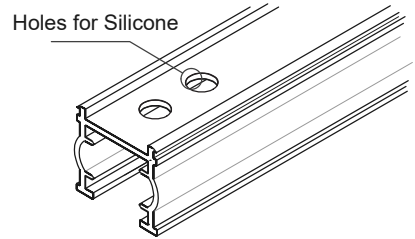

Edgetec® 220 Rail  
 Black EPDM Gasket (2900mm length)  
 for 12mm Glass 300593  
 for 15mm Glass 300594

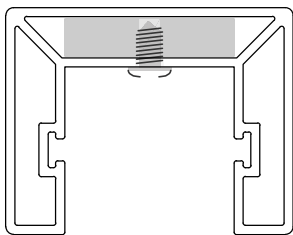

Joiners both 22.5 x 5mm  
 Aluminium

- Joiners: (After cutting extrusions to length)
- With Joiner in place, spot drill from below for position
  - Drill out to joiner to 3mm dia, extrusion to 4mm dia
  - Use No 6 x 1/4in SS ST Pan sq drive Screw (301993)

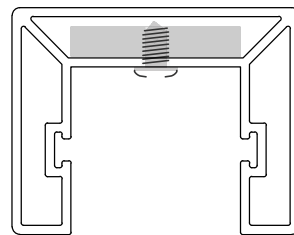

End Plate  
 Tabs all 22.5 x 4mm SS.

- End Plates: (After cutting extrusions to length)
- With End Plate in place, spot drill from below for position
  - Drill out to SS tab to 3mm dia, extrusion to 4mm dia
  - Use No 6 x 1/4in SS ST Pan sq drive Screw (301993)
  - End Plate must be securely attached to Post or structure.

**Joiners nom. 22.5 x 5mm Aluminium**

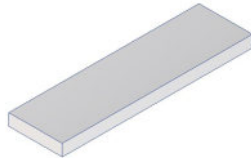

Edgetec® 220 Rail Inline Joiner (#300847)  
 80x22.5x5mm

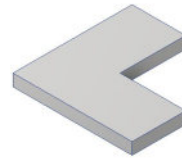

Edgetec® 220 Rail Fixed 90 Degree Joiner (#300848)  
 50x50x5mm

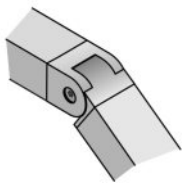

Edgetec® 220 Rail  
 Vertical Adjustable Joiner (#301990)

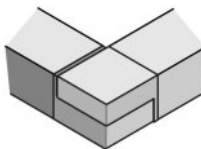

Edgetec® 220 Rail  
 Horizontal Fixed Joiner (#301985)

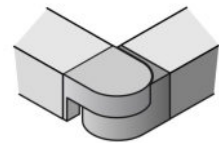

Edgetec® 220 Rail  
 Horizontal Adjustable Joiner (#301988)



Edgetec® 220 Rail  
 Wall Bracket Post End\* (#301992)  
 60x46mm

\* Suits AP65 Aluminium Post



Edgetec® 220 Rail  
 Wall Bracket Left Hand (#301004)  
 120x45mm



Edgetec® 220 Rail  
 Wall Bracket Right Hand (#301006)  
 120x45mm



Edgetec® 220 Rail  
 Wall Bracket Post End (#301149)  
 100x45mm

**Tabs all 22.5 x 4mm SS. Front faces all 3mm SS**

## POSIGLAZE RAIL & BRACKETS (DRAWING 09)

S25 RAIL conforming to NZS 4223.3.2016 and Building Code Clause B1/AS1 CI 7.3.1

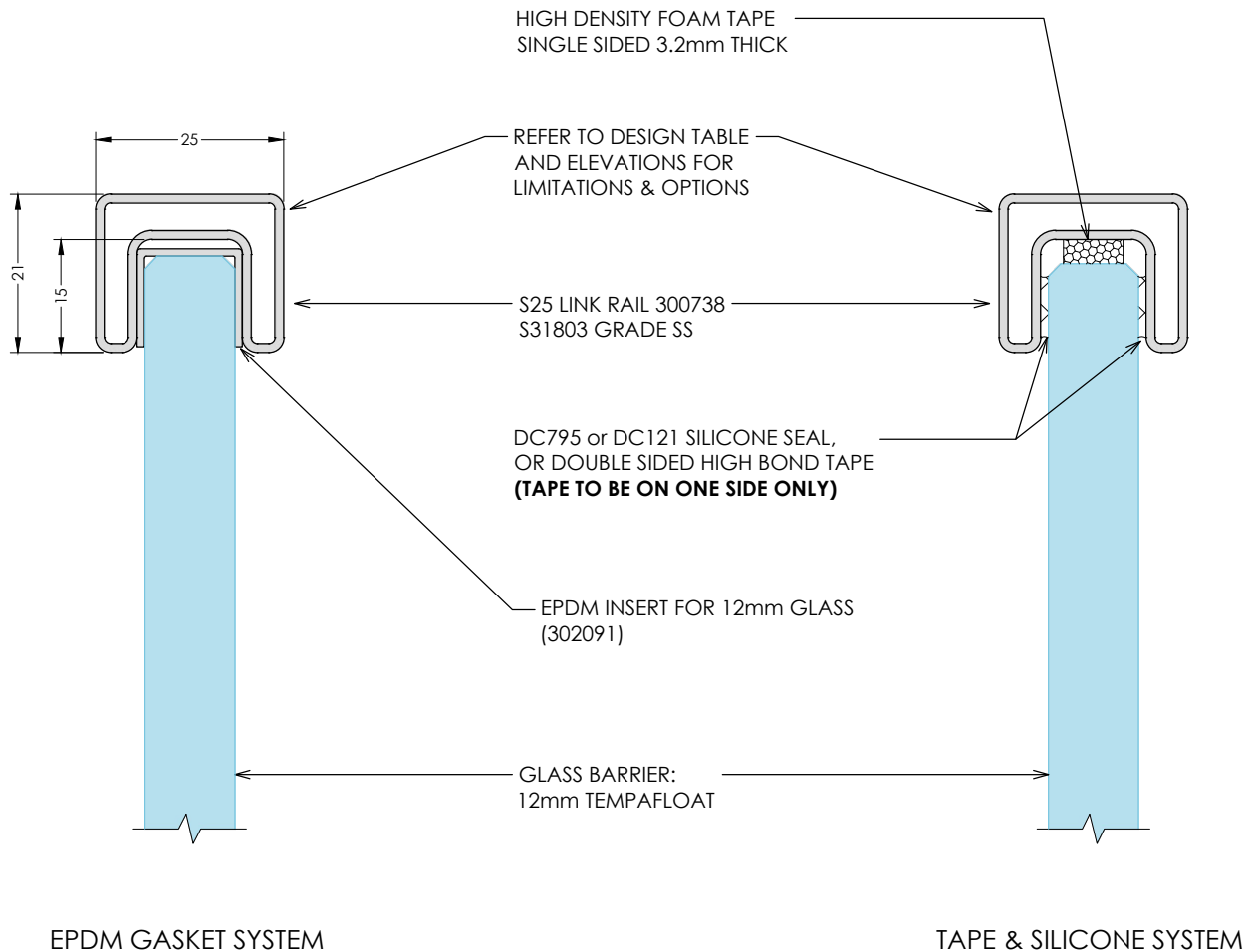

### S25-01 S25 RAIL - TYPICAL INSTALLATIONS

#### NOTES:

1. INTERLINKING RAIL DETAILS ARE ONLY TO BE USED ON METRO PERFORMANCE GLASS CANTILEVERED GLASS BALUSTRADES.
2. PREPARE FOR AND APPLY DC795 & DC121 STRUCTURAL SILICONE IN ACCORDANCE WITH DOW CORNING PREPARATION AND INSTALLATION INSTRUCTIONS.
3. INTERLINKING RAIL SPLICE & CORNER CONNECTIONS ARE SHOWN ON DRAWINGS S25-02 & S25-03
4. INTERLINKING RAIL END CONNECTION BRACKETS & ATTACHMENT DETAILS ARE SHOWN ON DRAWINGS S25-04 to S25-08.
5. ALL SCREWS TO BE STAINLESS STEEL WITH A MINIMUM ULTIMATE SHEAR STRENGTH OF 3.5kN (PER SCREW).
6. LINK RAIL SECTION AND CONNECTION PIECES TO BE S31803 GRADE STAINLESS STEEL, IN ACCORDANCE WITH NZS 4673:2001.
7. REFER TO WARRANTY & MAINTENANCE PAGES FOR PERIODIC INSPECTION, CLEANING & MAINTENANCE REQUIREMENTS.

**POSIGLAZE RAIL & BRACKETS (DRAWING 10)**

**S25 RAIL conforming to NZS 4223.3.2016 and Building Code Clause B1/AS1 CI 7.3.1**

ALL FIXINGS TO BE  
STAINLESS STEEL

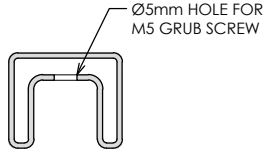

**S25 LINK RAIL SECTION  
300738**

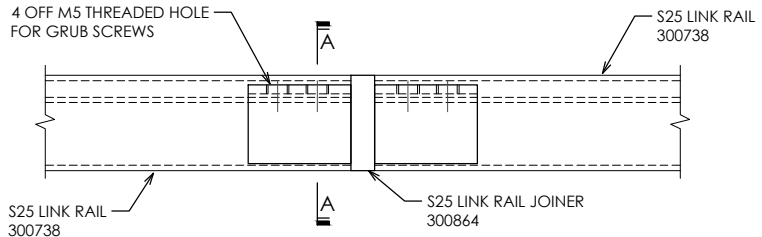

**S25 LINK RAIL - SPLICE CONNECTION ELEVATION**

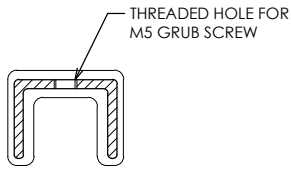

**S25 LINK RAIL  
INLINE JOINER  
300864**

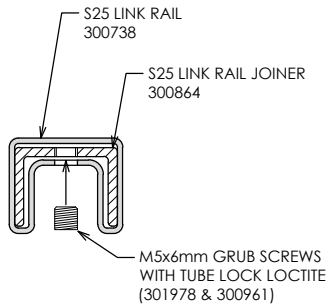

**SECTION A-A**

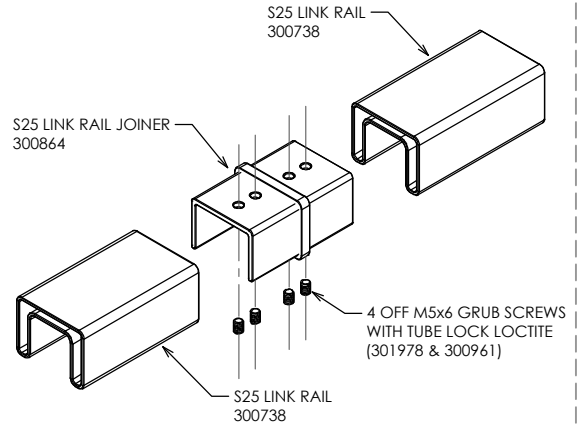

**S25-02**

**S25 RAIL - SPLICE CONNECTION DETAIL**

ALL FIXINGS TO BE  
STAINLESS STEEL

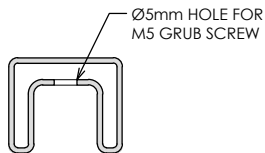

**S25 LINK RAIL SECTION  
300738**

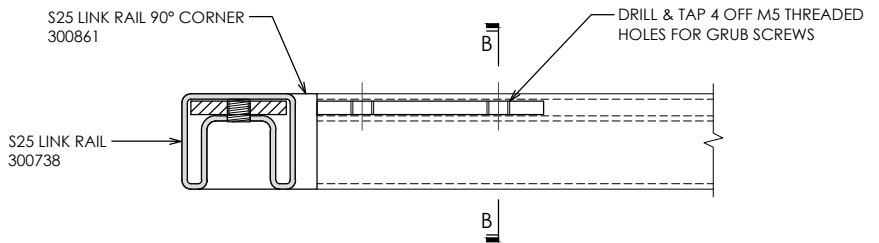

**S25 LINK RAIL - 90° CORNER CONNECTION ELEVATION**

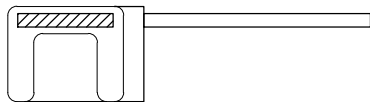

**S25 LINK RAIL 90° CORNER  
300861**

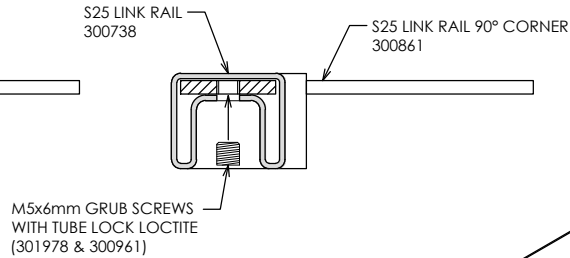

**SECTION B-B**

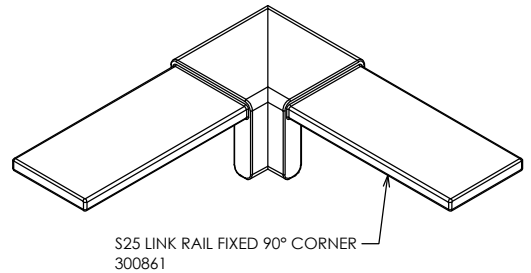

**S25-03**

**S25 RAIL - 90° CORNER CONNECTION DETAIL**

**POSIGLAZE RAIL & BRACKETS (DRAWING 11)**

**S25 RAIL conforming to NZS 4223.3.2016 and Building Code Clause B1/AS1 CI 7.3.1**

ALL FIXINGS TO BE  
STAINLESS STEEL

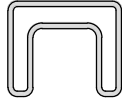

**S25 LINK RAIL SECTION  
300738**

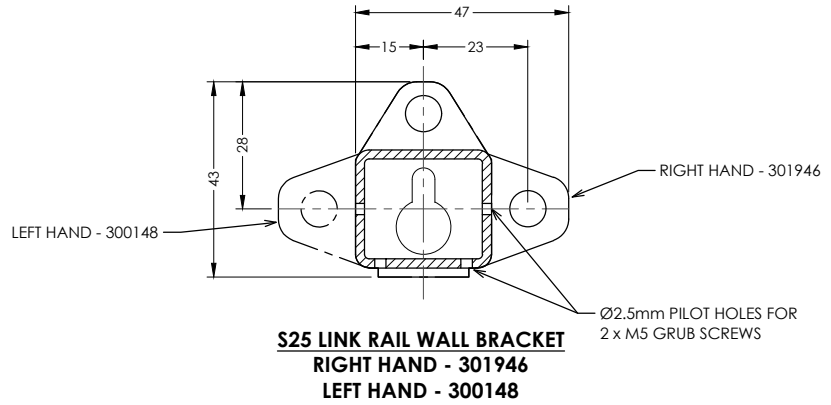

**S25 LINK RAIL WALL BRACKET  
RIGHT HAND - 301946  
LEFT HAND - 300148**

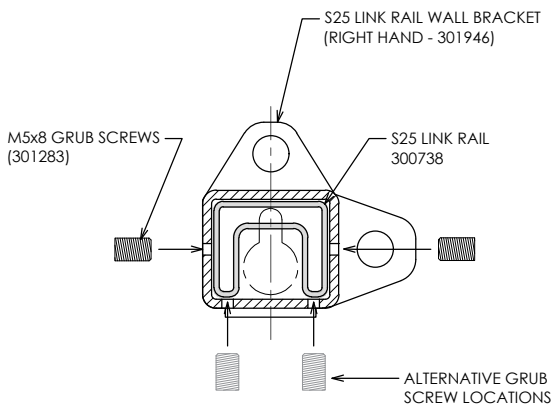

**SECTION C-C**

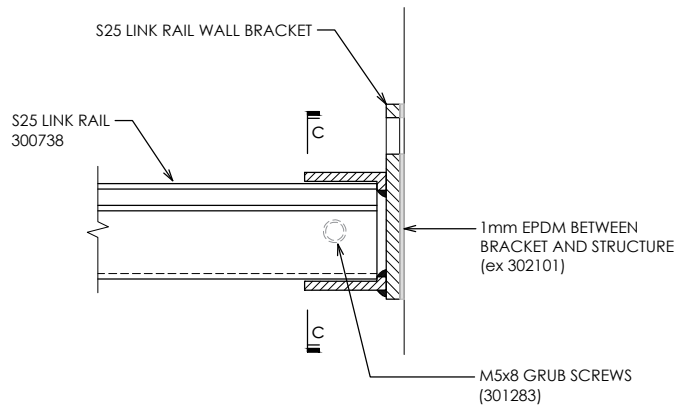

**S25 LINK RAIL - END BRACKET SECTION**

**S25-04  
S25 RAIL WALL BRACKET**

ALL FIXINGS TO BE  
STAINLESS STEEL

**NOTES:**

1. CONCRETE WALL IS TO BE DESIGNED BY PROJECT STRUCTURAL ENGINEER FOR LOADS IMPOSED BY BALUSTRADE. ULS POINT LOAD, N\* = 0.9KN - INWARDS, OUTWARDS OR DOWN.
2. CONCRETE WALL TO BE MINIMUM 140mm THICK.
3. CONCRETE WALL MUST BE REINFORCED & IS TO BE DESIGNED & DETAILED IN ACCORDANCE WITH NZS3101.
4. MINIMUM CONCRETE STRENGTH = 20MPa.

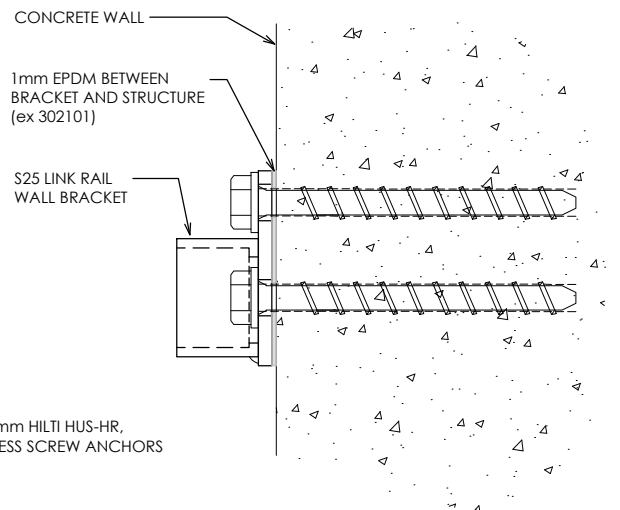
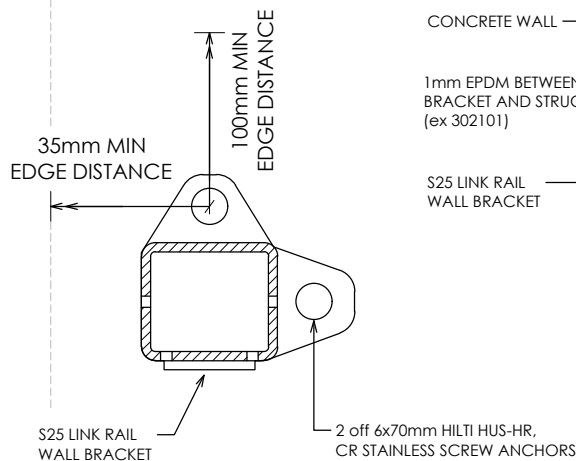

**S25-05  
S25 RAIL - END BRACKET CONCRETE WALL ATTACHMENT**

## POSIGLAZE RAIL & BRACKETS (DRAWING 12)

### S25 RAIL conforming to NZS 4223.3.2016 and Building Code Clause B1/AS1 Cl 7.3.1

ALL FIXINGS TO BE STAINLESS STEEL

**NOTES:**

1. BLOCKWALL IS TO BE DESIGNED BY PROJECT STRUCTURAL ENGINEER FOR LOADS IMPOSED BY BALUSTRADE. ULS POINT LOAD,  $N^* = 0.9kN$  - INWARDS, OUTWARDS OR DOWN.
2. MINIMUM BLOCKWALL THICKNESS = 140mm.
3. BLOCKWALL MUST BE COREFILLED / REINFORCED & IS TO BE DESIGNED & DETAILED IN ACCORDANCE WITH NZS4230 OR NZS4229.
4. MINIMUM COREFILL CONCRETE STRENGTH = 17.5MPa.

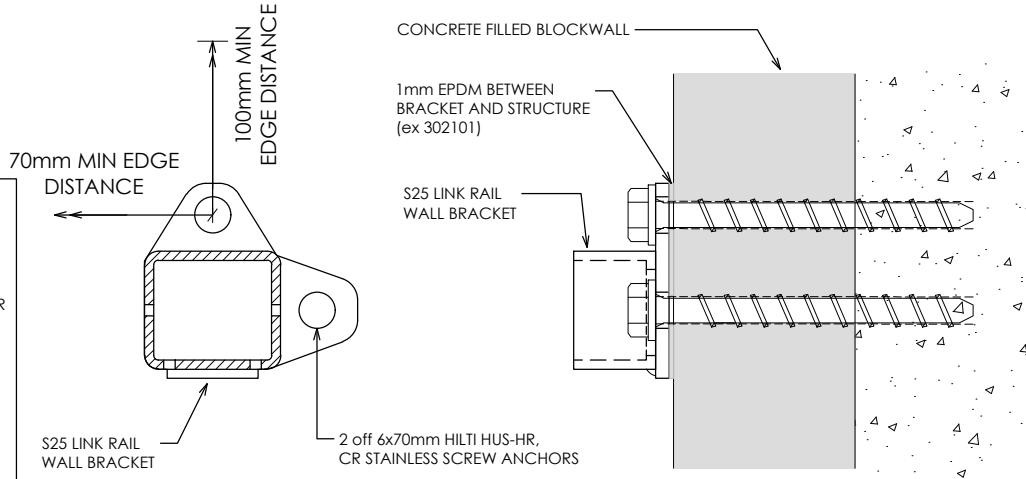

#### S25-06

#### S25 RAIL - END BRACKET BLOCKWALL ATTACHMENT

ALL FIXINGS TO BE STAINLESS STEEL

**NOTES:**

1. TIMBER STUD WALL IS TO BE DESIGNED BY PROJECT STRUCTURAL ENGINEER FOR LOADS IMPOSED BY BALUSTRADE. ULS POINT LOAD,  $N^* = 0.9kN$  - INWARDS, OUTWARDS OR DOWN.
2. MINIMUM STUD SIZE = 90x45.
3. MINIMUM TIMBER GRADE = SG8.
4. TIMBER STUD WALL TO BE DESIGNED & DETAILED IN ACCORDANCE WITH NZS3603 OR NZS3604.

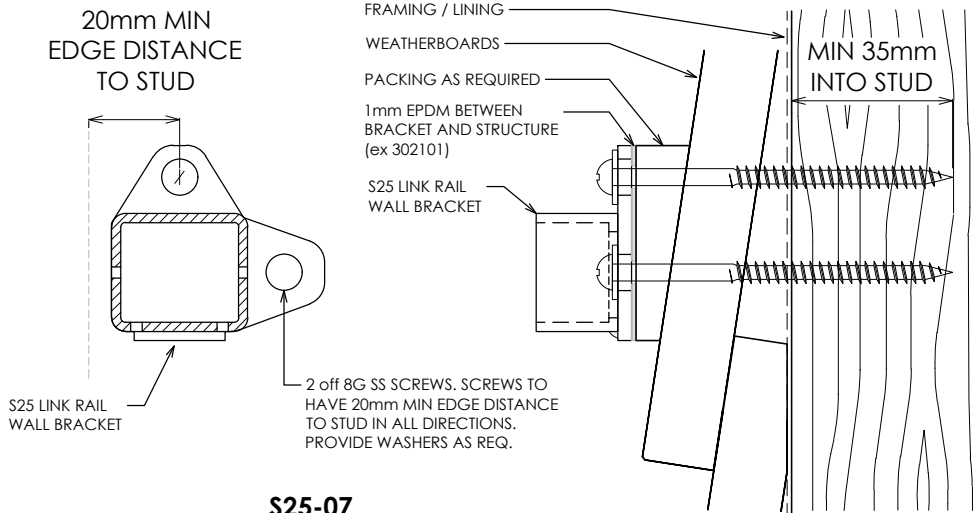

#### S25-07

#### S25 RAIL - END BRACKET WEATHERBOARD ATTACHMENT

ALL FIXINGS TO BE STAINLESS STEEL

**NOTES:**

1. STEEL POST IS TO BE DESIGNED BY PROJECT STRUCTURAL ENGINEER FOR LOADS IMPOSED BY BALUSTRADE. ULS POINT LOAD,  $N^* = 0.9kN$  - INWARDS, OUTWARDS OR DOWN.
2. BUILDING DESIGNER TO ENSURE DURABILITY REQUIREMENTS OF CONNECTION ARE MET.
3. MINIMUM STEEL POST WALL THICKNESS = 5mm.
4. MINIMUM STEEL GRADE = 300MPa.

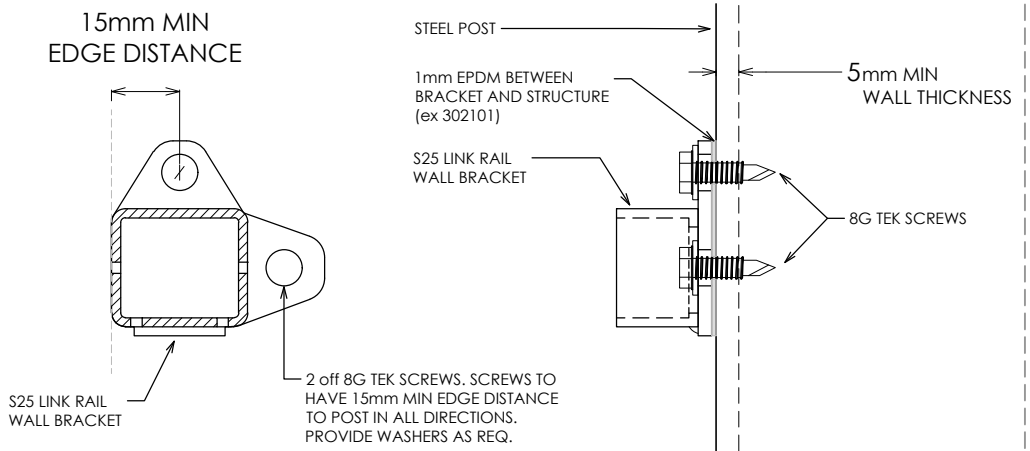

#### S25-08

#### S25 RAIL - END BRACKET STEEL POST ATTACHMENT

**POSIGLAZE RAIL & BRACKETS (DRAWING 13)**  
**S40 RAIL conforming to NZS 4223.3.2016 and Building Code Clause B1/AS1 CI 7.3.1**

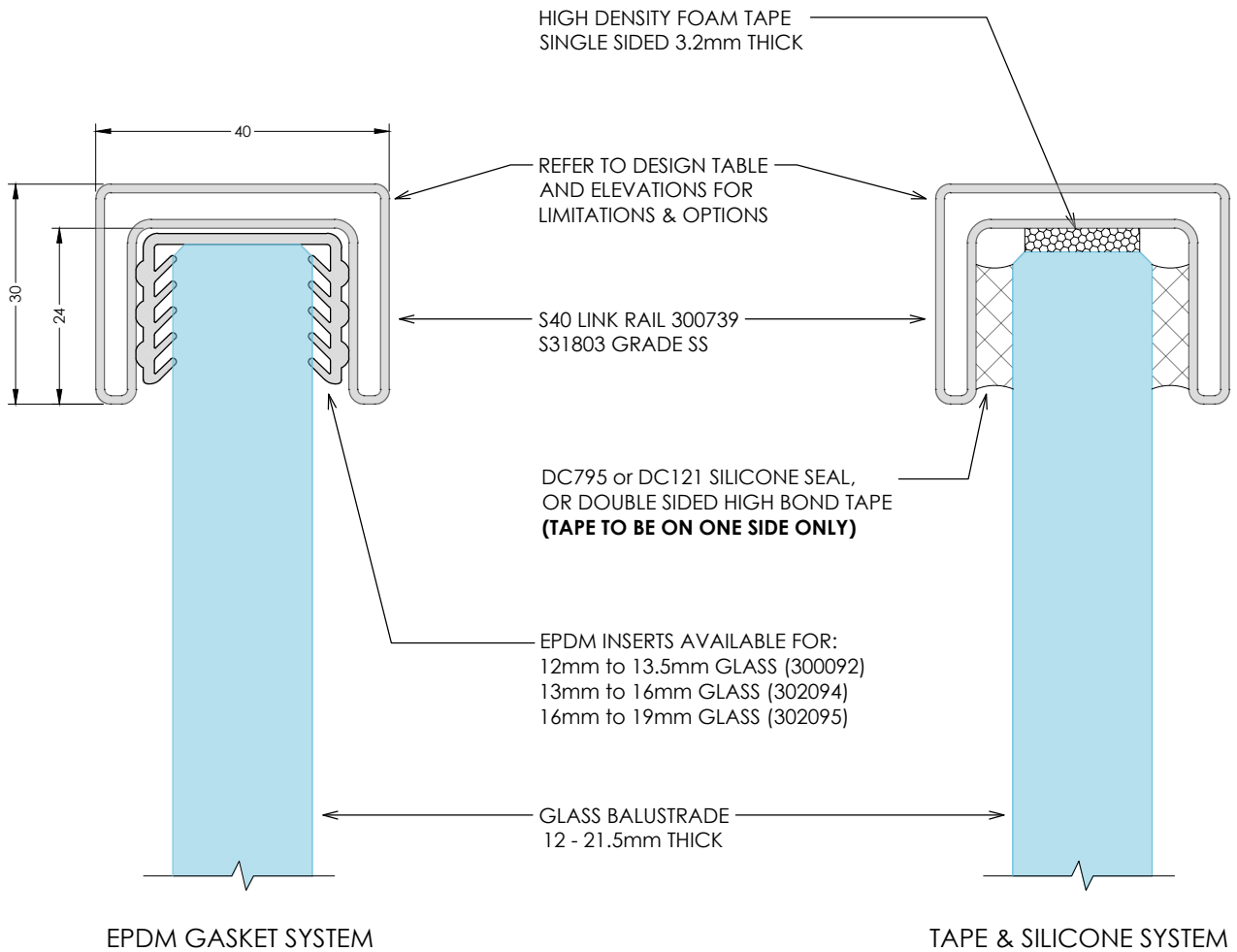

EPDM GASKET SYSTEM

TAPE & SILICONE SYSTEM

**S40-01**  
**S40 RAIL - TYPICAL INSTALLATIONS**

**NOTES:**

1. INTERLINKING RAIL DETAILS ARE ONLY TO BE USED ON METRO PERFORMANCE GLASS CANTILEVERED GLASS BALUSTRADES.
2. PREPARE FOR AND APPLY DC795 & DC121 STRUCTURAL SILICONE IN ACCORDANCE WITH DOW CORNING PREPARATION AND INSTALLATION INSTRUCTIONS.
3. INTERLINKING RAIL SPLICE & CORNER CONNECTIONS ARE SHOWN ON DRAWINGS S40-02 & S40-03
4. INTERLINKING RAIL END CONNECTION BRACKETS & ATTACHMENT DETAILS ARE SHOWN ON DRAWINGS S40-04 to S40-08.
5. ALL SCREWS TO BE STAINLESS STEEL WITH A MINIMUM ULTIMATE SHEAR STRENGTH OF 3.5KN (PER SCREW).
6. LINK RAIL SECTION AND CONNECTION PIECES TO BE S31803 GRADE STAINLESS STEEL, IN ACCORDANCE WITH NZS 4673:2001.
7. REFER TO WARRANTY & MAINTENANCE PAGES FOR PERIODIC INSPECTION, CLEANING & MAINTENANCE REQUIREMENTS.

**POSIGLAZE RAIL & BRACKETS (DRAWING 14)**

**S40 RAIL conforming to NZS 4223.3.2016 and Building Code Clause B1/AS1 CI 7.3.1**

ALL FIXINGS TO BE STAINLESS STEEL

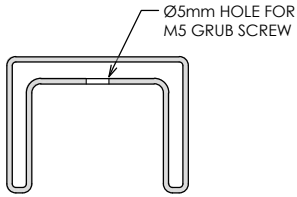

**S40 LINK RAIL SECTION 300739**

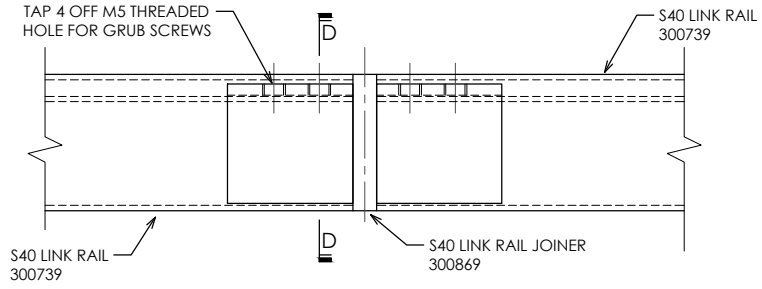

**S40 LINK RAIL - SPLICE CONNECTION ELEVATION**

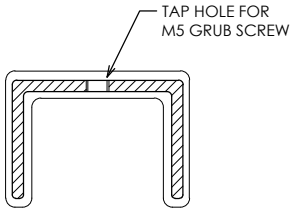

**S40 LINK RAIL INLINE JOINER 300869**

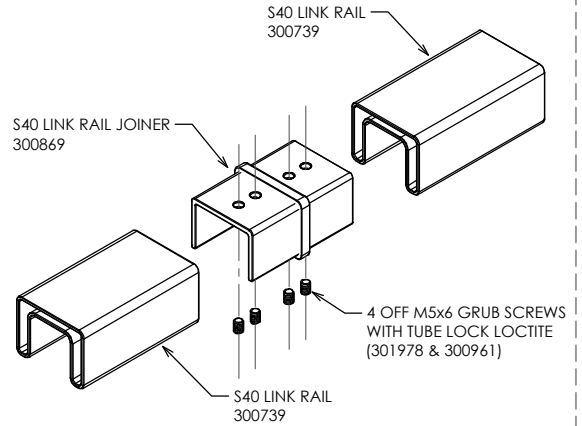
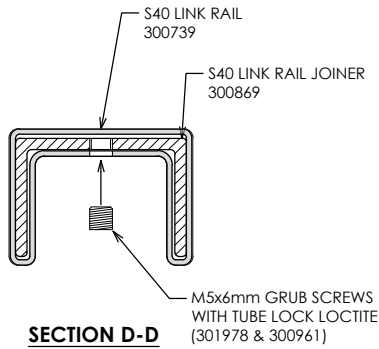

**S40-02**

**S40 RAIL - SPLICE CONNECTION DETAIL**

ALL FIXINGS TO BE STAINLESS STEEL

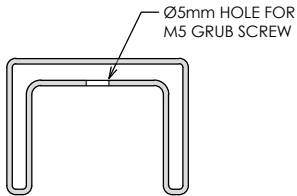

**S40 LINK RAIL SECTION 300739**

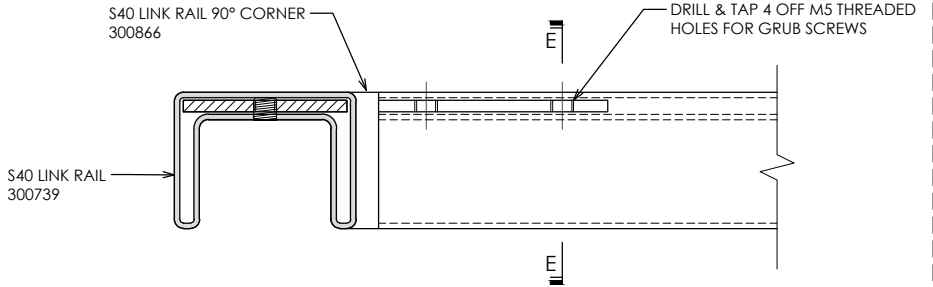

**S40 LINK RAIL - 90° CORNER CONNECTION ELEVATION**

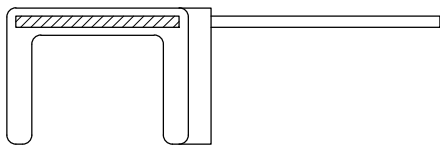

**S40 LINK RAIL 90° CORNER 300866**

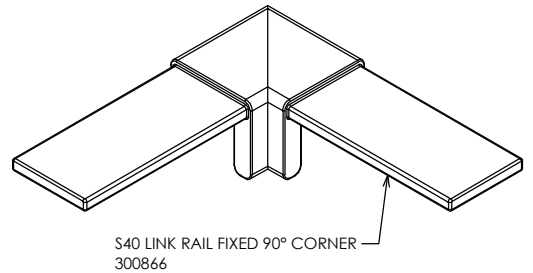
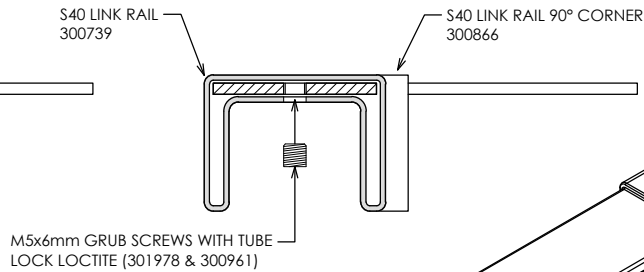

**S40-03**

**S40 RAIL - 90° CORNER CONNECTION DETAIL**

**POSIGLAZE RAIL & BRACKETS (DRAWING 15)**

**S40 RAIL conforming to NZS 4223.3.2016 and Building Code Clause B1/AS1 CI 7.3.1**

ALL FIXINGS TO BE  
STAINLESS STEEL

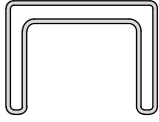

**S40 LINK RAIL SECTION  
300739**

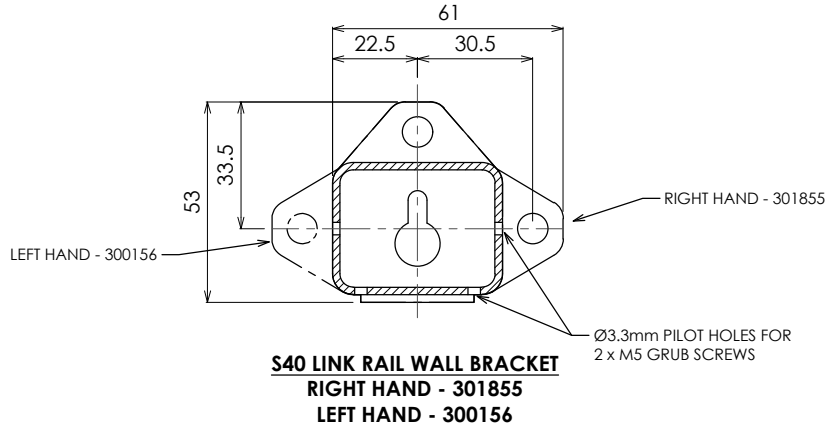

**S40 LINK RAIL WALL BRACKET  
RIGHT HAND - 301855  
LEFT HAND - 300156**

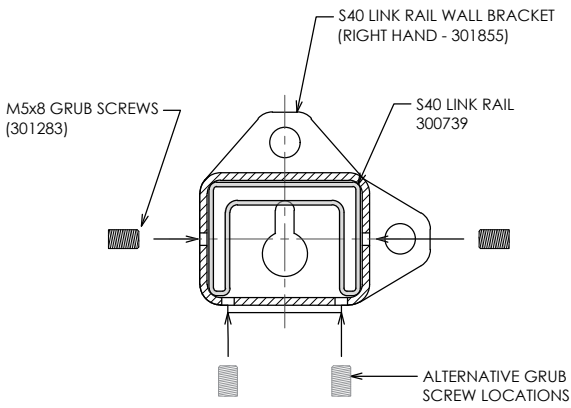

**SECTION F-F**

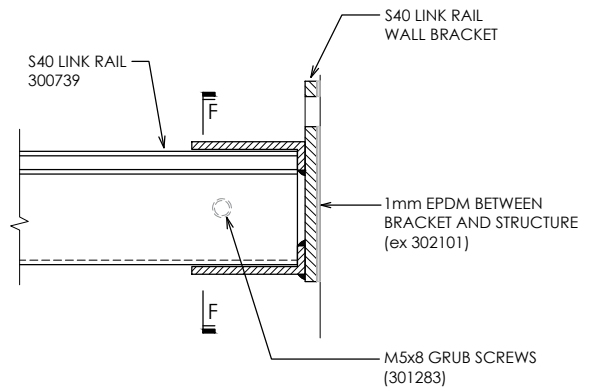

**S40 LINK RAIL - END BRACKET SECTION**

**S40-04  
S40 RAIL WALL BRACKET**

ALL FIXINGS TO BE  
STAINLESS STEEL

**NOTES:**

1. CONCRETE WALL IS TO BE DESIGNED BY PROJECT STRUCTURAL ENGINEER FOR LOADS IMPOSED BY BALUSTRADE. ULS POINT LOAD, N\* = 0.9KN - INWARDS, OUTWARDS OR DOWN.
2. CONCRETE WALL TO BE MINIMUM 140mm THICK.
3. CONCRETE WALL MUST BE REINFORCED & IS TO BE DESIGNED & DETAILED IN ACCORDANCE WITH NZS3101.
4. MINIMUM CONCRETE STRENGTH = 20MPa.

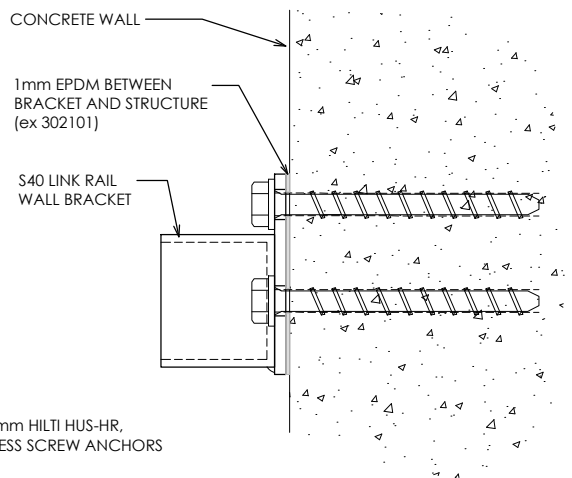
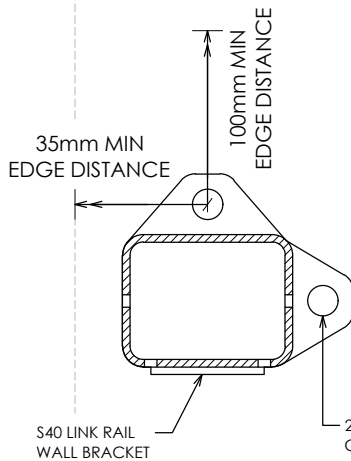

**S40-05  
S40 RAIL - END BRACKET CONCRETE WALL ATTACHMENT**



## POSIGLAZE RAIL & BRACKETS (DRAWING 16)

**S40 RAIL conforming to NZS 4223.3.2016 and Building Code Clause B1/AS1 Cl 7.3.1**

ALL FIXINGS TO BE  
STAINLESS STEEL

**NOTES:**

1. BLOCKWALL IS TO BE DESIGNED BY PROJECT STRUCTURAL ENGINEER FOR LOADS IMPOSED BY BALUSTRADE. ULS POINT LOAD,  $N^* = 0.9KN$  - INWARDS, OUTWARDS OR DOWN.
2. MINIMUM BLOCKWALL THICKNESS = 140mm.
3. BLOCKWALL MUST BE COREFILLED / REINFORCED & IS TO BE DESIGNED & DETAILED IN ACCORDANCE WITH NZS4230 OR NZS4229.
4. MINIMUM COREFILL CONCRETE STRENGTH = 17.5MPa.

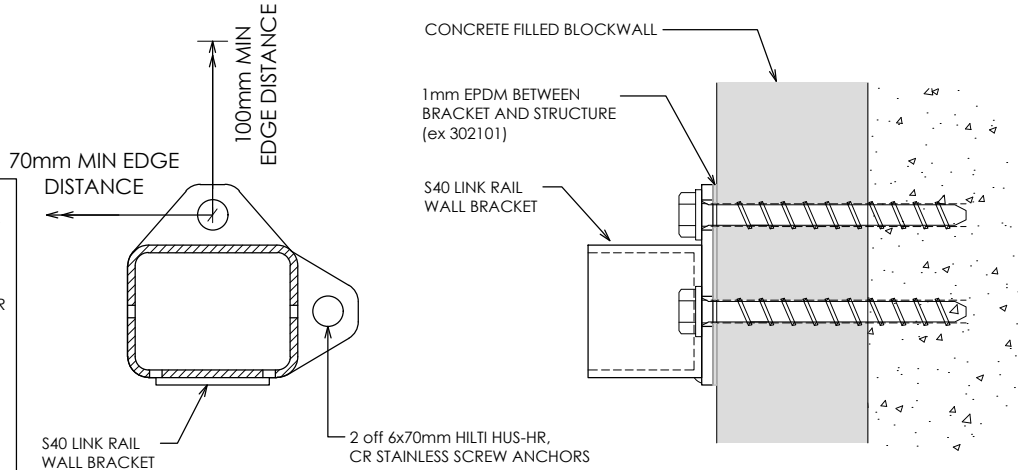

**S40-06**

**S40 RAIL - END BRACKET BLOCKWALL ATTACHMENT**

ALL FIXINGS TO BE  
STAINLESS STEEL

**NOTES:**

1. TIMBER STUD WALL IS TO BE DESIGNED BY PROJECT STRUCTURAL ENGINEER FOR LOADS IMPOSED BY BALUSTRADE. ULS POINT LOAD,  $N^* = 0.9KN$  - INWARDS, OUTWARDS OR DOWN.
2. MINIMUM STUD SIZE = 90x45.
3. MINIMUM TIMBER GRADE = SG8.
4. TIMBER STUD WALL TO BE DESIGNED & DETAILED IN ACCORDANCE WITH NZS3603 OR NZS3604.

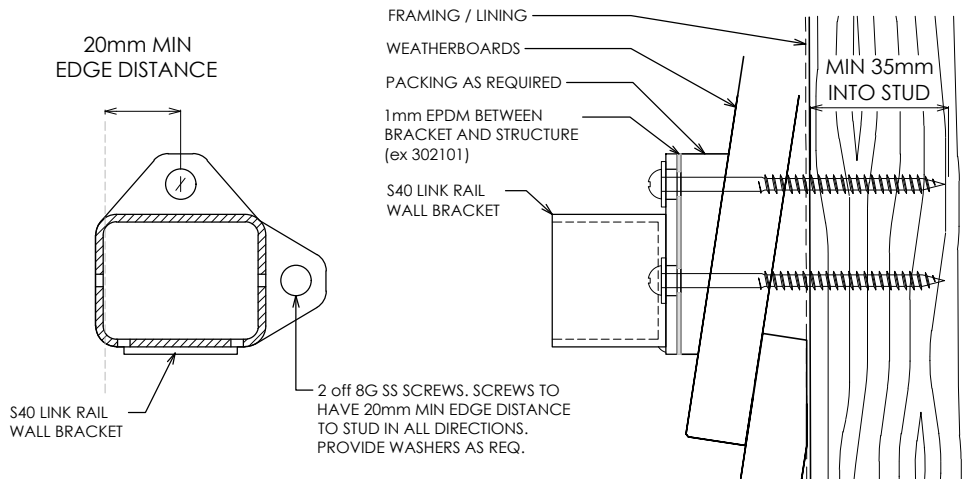

**S40-07**

**S40 RAIL - END BRACKET WEATHERBOARD ATTACHMENT**

ALL FIXINGS TO BE  
STAINLESS STEEL

**NOTES:**

1. STEEL POST IS TO BE DESIGNED BY PROJECT STRUCTURAL ENGINEER FOR LOADS IMPOSED BY BALUSTRADE. ULS POINT LOAD,  $N^* = 0.9KN$  - INWARDS, OUTWARDS OR DOWN.
2. BUILDING DESIGNER TO ENSURE DURABILITY REQUIREMENTS OF CONNECTION ARE MET.
3. MINIMUM STEEL POST WALL THICKNESS = 5mm.
4. MINIMUM STEEL GRADE = 300MPa.

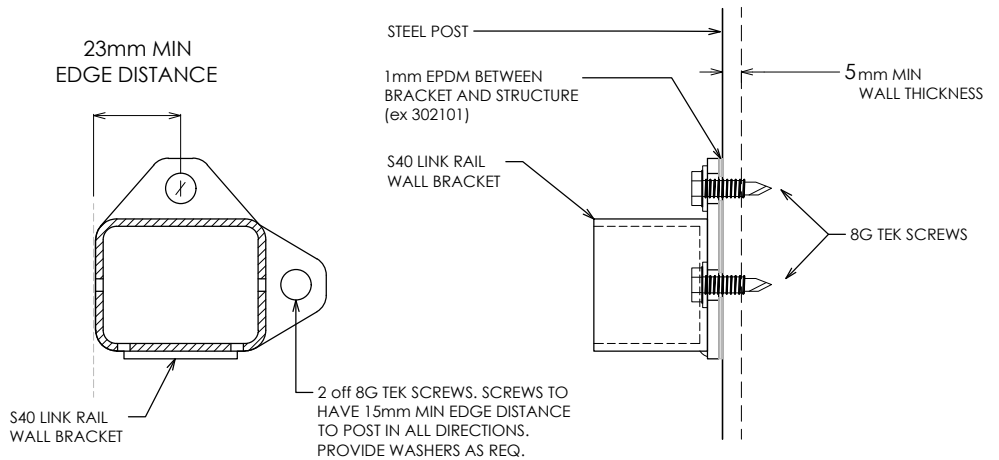

**S40-08**

**S40 RAIL - END BRACKET STEEL POST ATTACHMENT**

**POSIGLAZE RAIL & BRACKETS (DRAWING 17)**

**Interlinking Top Rail conforming to NZS 4223.3.2016 and Building Code Clause B1/AS1 CI 7.3.1  
For attaching EDGETEC<sup>®</sup> (on glass) to a Semi Frameless AP65 Post (where wall fixing not suitable)**

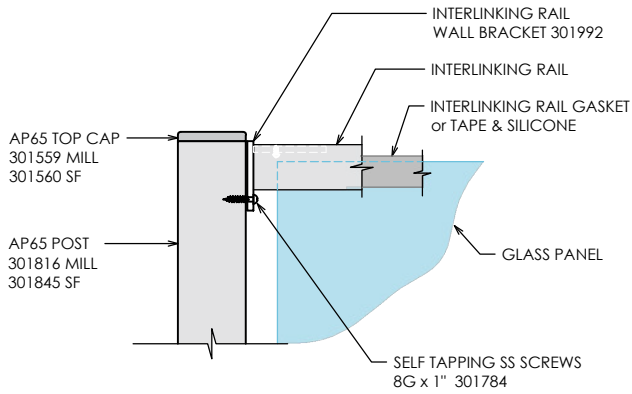

**AP65 Structural Post & Edgetec<sup>®</sup> Rail  
Side Elevation**

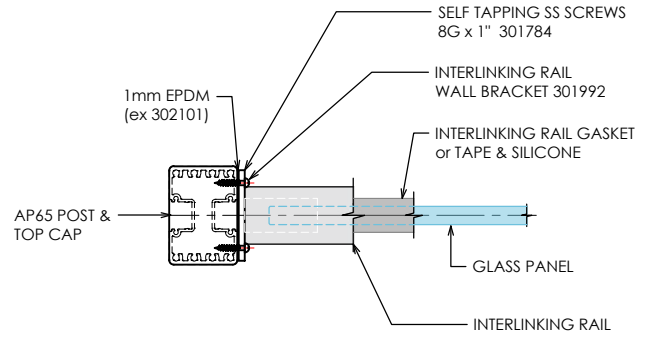

**AP65 Structural Post & Edgetec<sup>®</sup> Rail  
Plan**

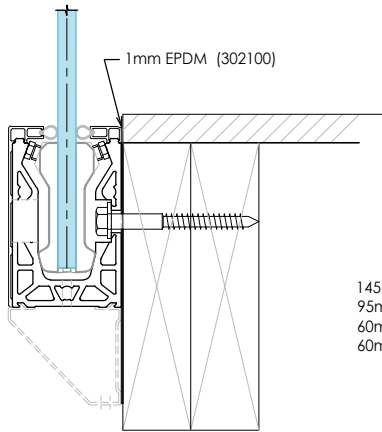

**PosiGlaze Side Fix**

145mm for 10mm coachscrews to 2x190x45 joists.  
95mm for M10 bolts & nuts to 2x140x45 joists.  
60mm for M10 bolts & nuts to steel.  
60mm for M10 studs to concrete.

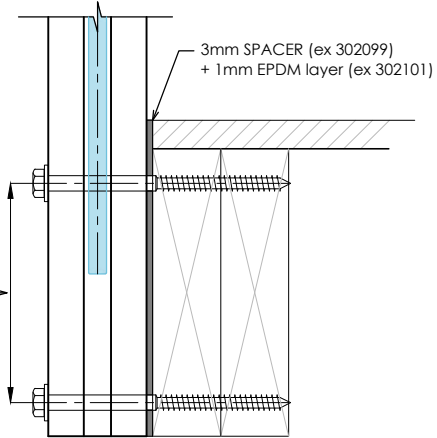

**Edgetec<sup>®</sup> Rail & AP65 Semi Frameless Post Extrusion  
Side Fix Post as an end Post**

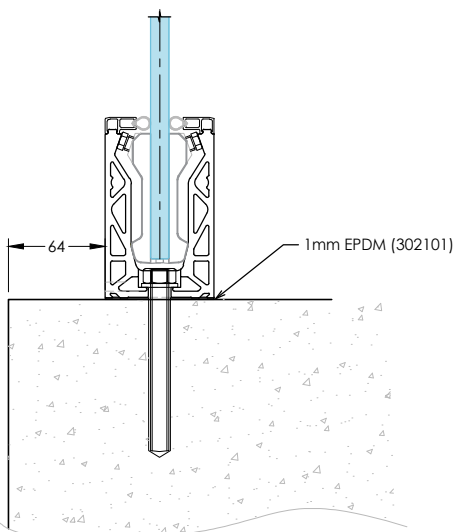

**PosiGlaze Base Fix**

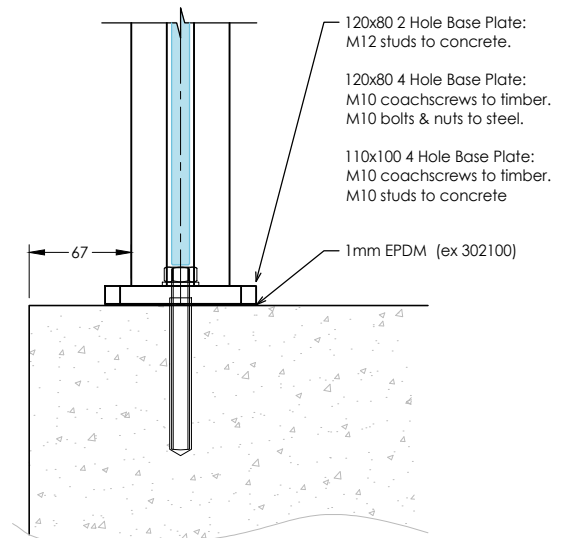

**AP65 Semi Frameless Post Extrusion  
Base Fix Post as an end Post**

**POSIGLAZE RAIL & BRACKETS (DRAWING 18)**

**Interlinking Top Rail conforming to NZS 4223.3.2016 and Building Code Clause B1/AS1 CI 7.3.1  
For attaching S25 (on glass) to a Semi Frameless AP65 Post (where wall fixing not suitable)**

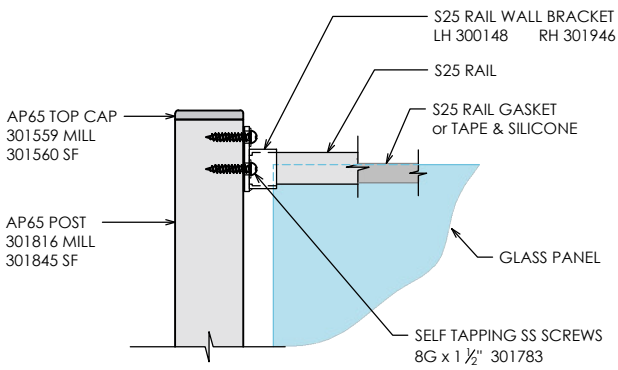

**AP65 Structural Post & S25 Rail  
Side Elevation**

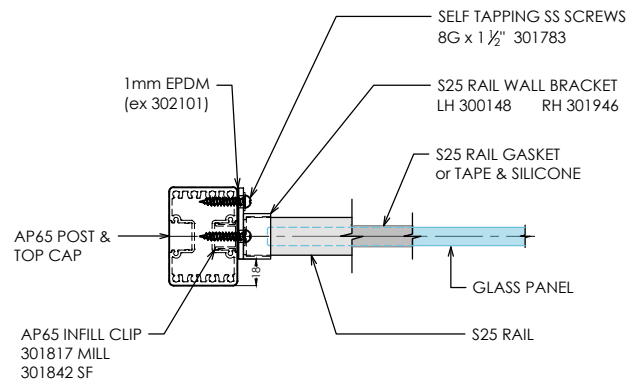

**AP65 Structural Post & S25 Rail  
Plan**

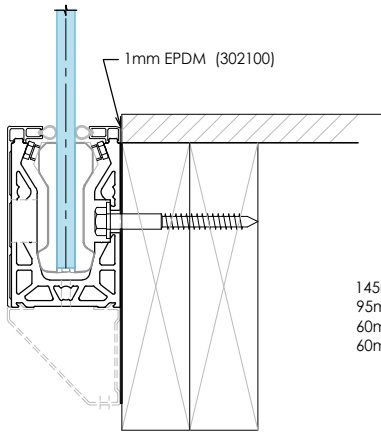

**PosiGlaze Side Fix**

145mm for 10mm coachscrews to 2x190x45 joists.  
95mm for M10 bolts & nuts to 2x140x45 joists.  
60mm for M10 bolts & nuts to steel.  
60mm for M10 studs to concrete.

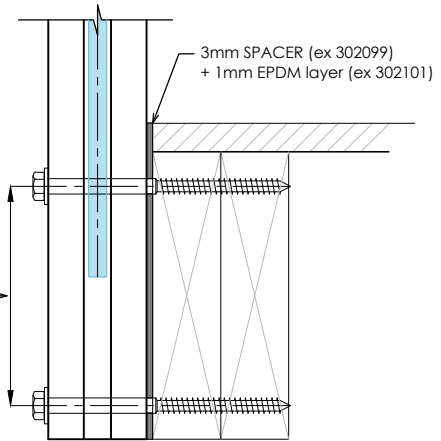

**S25 Rail & AP65 Semi Frameless Post Extrusion  
Side Fix Post as an end Post**

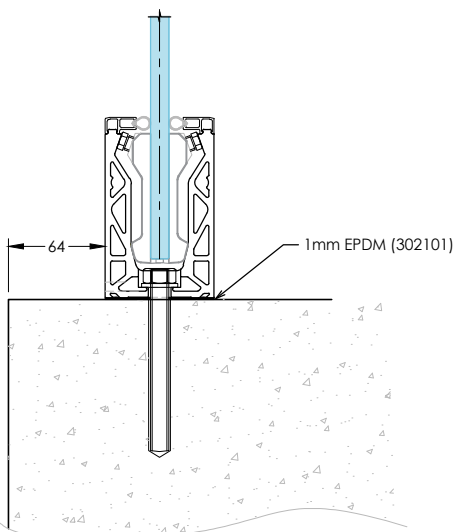

**PosiGlaze Base Fix**

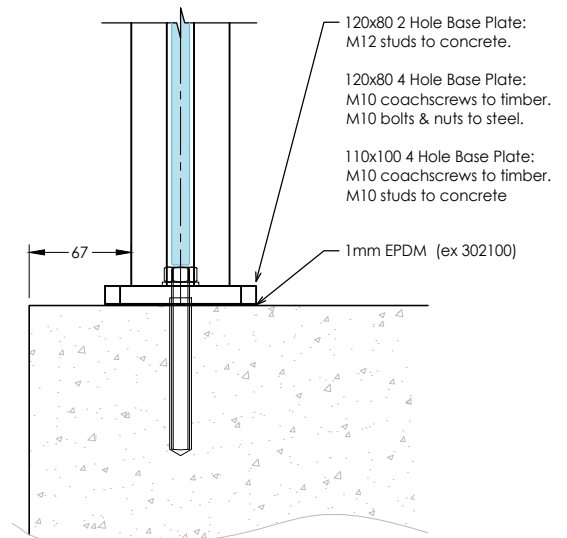

**AP65 Semi Frameless Post Extrusion  
Base Fix Post as an end Post**

## POSIGLAZE RAIL & BRACKETS (DRAWING 19)

Interlinking Top Rail conforming to NZS 4223.3.2016 and Building Code Clause B1/AS1 Cl 7.3.1  
For attaching S40 (on glass) to a Semi Frameless AP78 Post (where wall fixing not suitable)

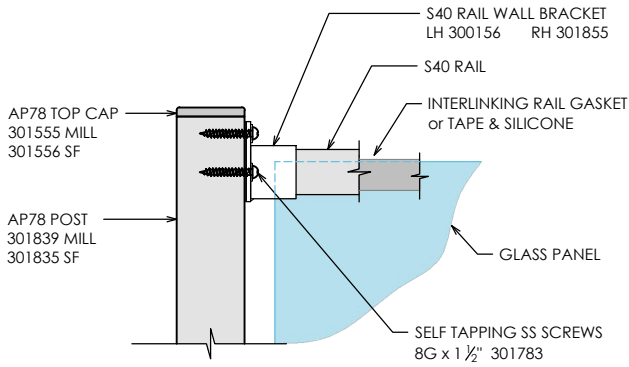

**AP78 Structural Post & S40 Rail  
Side Elevation**

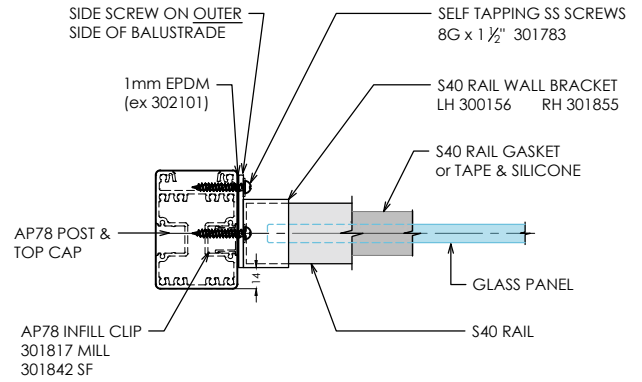

**AP78 Structural Post & S40 Rail  
Plan**

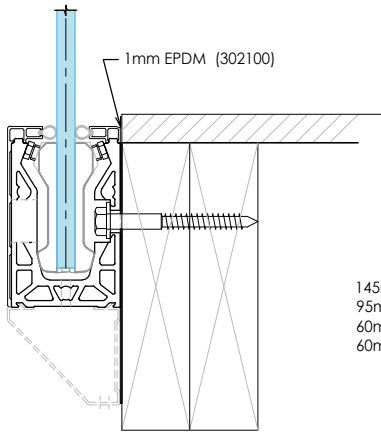

**PosiGlaze Side Fix**

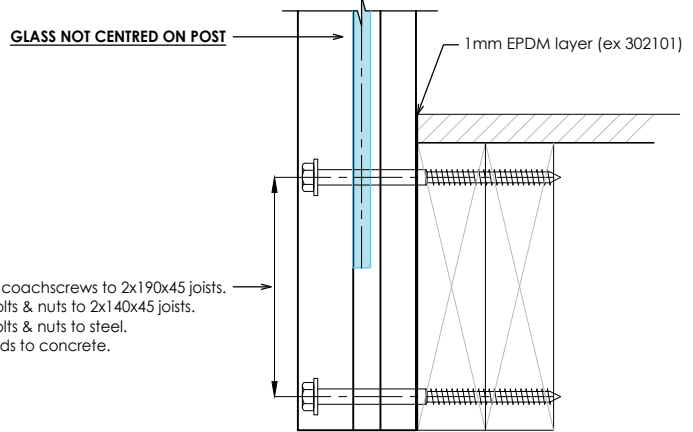

**S40 Rail & AP78 Semi Frameless Post Extrusion  
Side Fix Post as an end Post**

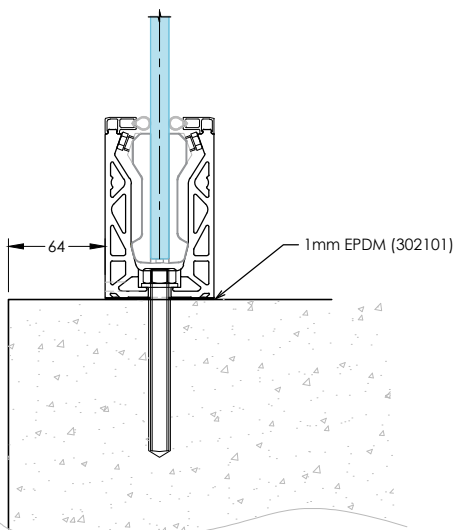

**PosiGlaze Base Fix**

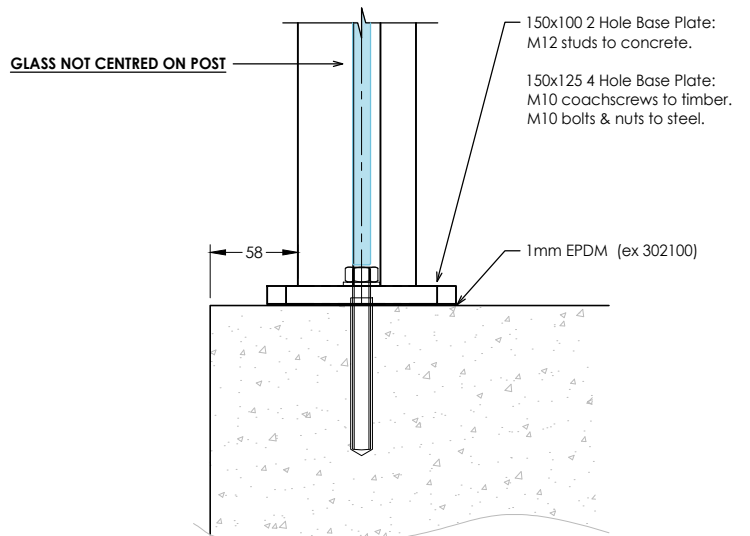

**AP78 Semi Frameless Post Extrusion  
Base Fix Post as an end Post**

### CARE AND MAINTENANCE OF METRO PERFORMANCE GLASS HARDWARE

Hardware requires regular maintenance to ensure the system performs at its best. As a general rule, the harsher the environment, the more regular the maintenance required to keep your hardware in top condition. Also hardware or systems that are covered by verandas or wide eaves and not subject to natural rain wash needs regular cleaning to avoid damage to surface finish on both the aluminium and any surface coated hardware.

Fair wear and tear;

The following maintenance tasks are not covered by this warranty:

- **Seals and rubbers** will require replacing from time to time depending on the environment. As a general rule, they should last for 10 years or more, and can be replaced by service provider.
- **Tracks, rollers** (if accessible) and hardware require lubrication; rollers may require replacing due to normal wear and tear. This depends on the environment and amount of use.

### CARE AND MAINTENANCE, WASHING GLASS

Regular washing and drying of glass windows and doors are required to ensure their long term durability. In urban areas washing should be done every three to six months.

The following guidelines apply:

- When washing, soak the glass surface with warm water and a mild soap detergent solution or proprietary glass cleaners to loosen dirt and debris.
- Use a soft grit free cloth or sponge when washing and try to avoid washing in direct sunlight. Do not use scrapers or razor blades.
- After washing, rinse with clean water and then dry the glass using a clean, grit-free squeegee, cloth, or paper towel. Remember, wet glass is dirty glass.
- All water and cleaning solution residue should be dried from the window gaskets, sealants, and frames to prevent water spots.
- Avoid cleaning tinted and reflective glass surfaces in direct sunlight. When washing special glass, the following guidelines apply:
  - When washing double glazing and laminated glass, use the same procedures as above but ensure no solvents come into contact with the edge laminate interlayer or unit sealant.
  - With reflective or Low E coated surfaces, exercise special care when cleaning - special cleaners may be required as they can be hard to clean. Follow manufacturer's instructions.
- It is advisable to check that frame drainage is not blocked this can affect laminate and insulated glass units.

### EZYCLEAN GLASS SURFACE COATING TECHNOLOGY

**Simple maintenance:** A soft cloth is all you really need to clean your protected glass, but for best results, squeegee dry after each use. The only cleaning solution Metro recommends using is warm water and mild detergent.

- Provided the glass is maintained according to published after-care instructions and without the use of abrasive cleaning methods or highly alkaline products, Metro Performance Glass warrants that Metro EzyClean Technology will work for up to ten (10) years from the date of manufacture.

Dos and don'ts a summary;

#### DO NOT:

- Do Not Use Scrapers of any type or size on a Glass surface.
- Do Not - Leave building dirt or residues to remain on Glass for a period of time.
- Do Not - Begin cleaning glass until you have identified the surface type.
- Do Not - Clean Glass surfaces in direct sunlight.
- Do Not - Allow dirty water or cleaning residues to remain on the Glass.
- Do Not - Begin cleaning before rinsing off loose residues.
- Do Not - Use abrasive cleaning solutions, materials or solvents.
- Do Not - Allow metal parts of the cleaning equipment to come in contact with the Glass.
- Do Not - Trap abrasive particles between the cleaning material and the Glass.

### DO:

- Clean glass promptly when dirt or building residues appear.
- Determine glass surface type.
- Exercise special care when cleaning coated surfaces.
- Avoid cleaning glass surfaces in direct sunlight.
- Start cleaning at the top of a building, then continue to lower levels.
- Soak the glass surface in a clean soapy solution before cleaning.
- Use a mild non abrasive commercial cleaner.
- Use a squeegee to remove all cleaning solution.
- Try your procedures on a small window and check.
- Caution other trades re the care and protection of the glass surfaces.

### CARE AND MAINTENANCE OF POWDERCOATING

Powder coating is available in a wide range of colours with commercially available surface integrity warranties from 10 to 30 years. The powder coating surface warranty period is conditional upon the formulation and micron thickness. Over time with exposure to the elements, powder coatings may show signs of weathering such as loss of gloss, chalking and slight color change. A simple regular clean will minimise the effects of weathering and will remove dirt, grime and other build-up detrimental to all powder coatings.

1. MPG uses Orica's Dulux Duralloy® and Duratec® architectural powder coatings in most instances, as well as AkzoNobel's Interpon D1000, Interpon D1010 Premium Residential, Interpon D1010 Premium Commercial, Interpon D2015 Ultriva™, Interpon D3020 Fluoromax® which can all be specified upon request. Different warranty periods for both film and colour integrity for all exterior and interior applications apply.

The frequency of such cleaning will depend on many factors including the:

- Geographical location of the building.
- Environment surrounding the building e.g. marine, industrial, alkaline or acidic, etc.
- Levels of atmospheric pollution including salts.
- Prevailing winds and the possibility of air borne debris causing erosive wear of the coating e.g. sand causing abrasion.
- Protection of part or all of the building by other buildings.
- Change in environmental circumstances during the lifetime of the building e.g. if rural became industrial.

The following guidelines apply:

- g. Just a gentle clean with a soft brush and mild detergent, followed by a fresh water rinse, will maintain the long-term performance of the powder coated or anodised aluminium. In rural or normal urban environments cleaning should occur every six months. In areas of high pollution, such as industrial areas, geothermal areas or coastal environments, cleaning should occur every three months. In particularly hazardous locations, such as beachfronts, severe marine environments or areas of high industrial pollution, cleaning should be increased to monthly.
- h. Sheltered areas can be at more risk of coating degradation than exposed areas. This is because wind-blown salt and other pollutants may adhere to the surface. These areas should be inspected and cleaned if necessary on a more regular basis.
- i. Adequate on site protection of delivered and/or installed hardware must be provided. Hardware may get knocked, scratched, or splattered with mortar, plaster, or paint during the later stages of construction. If splashes occur immediately wash down the hardware unit affected with water or methylated spirits\* (\*wash area thoroughly afterwards). Do not allow splashes to harden.
- j. To restore powder coated surfaces that have lost gloss or are chalking, polishing with a high quality crème polish in accordance with the manufacturer's instructions is recommended. Avoid polishes that contain cutting compounds, unless the surface is extremely weathered.

**DO NOT USE SOLVENTS** Strong solvent type cleaners should not be used. These are harmful to the extended life of your hardware system.

### CARE AND MAINTENANCE OF ANODISING

Anodised hardware is not only attractive, but also offers a durable and tough wearing finish. Some deterioration of the anodic oxide coating may occur, mainly as a result of grime deposition and subsequent attack by moisture, particularly if the moisture is contaminated with sulphur compounds.

Regular cleaning is essential to preserve the finish of anodised aluminium over a long period. The following guidelines apply:

- g. Anodised aluminium should be washed with warm water and a suitable wetting agent or mild soap solution, in a similar manner to washing a car. A fine brush may be used to loosen dirt or grime. The use of anything stiffer or more abrasive may result in damage to the surface. Acid or alkali cleaners should not be used, as these will damage anodic films and may discolour coloured hardware.
- h. Where greasy deposits or hard to remove grime is present, the anodising may be cleaned with a soft cloth dipped in white spirit, turpentine, kerosene, or a mild liquid scourer, followed by wiping it with a dry rag. However, the cleaner must ensure none of these solvents come into contact with other parts of the system. All solvents must be kept from contact with the Santoprene glazing gasket materials (the “rubber” seal around the glass), as most solvents will damage them.
- i. It is essential to rinse anodised aluminium thoroughly with copious applications of clean water after cleaning, particularly where crevices are present, and then dry the glass to prevent water spots.

Regularly washing anodised hardware will ensure a long lasting product. In general, the following programme is recommended:

- Rural environments: every six months.
- Urban environments: every three months.
- Industrial and marine environments: every six months, as well as a monthly cold water wash.

For additional protection, especially in harsh environments, waxing with a good quality car wax after washing will assist in lifting and maintaining the appearance of your anodised hardware.

Damage to anodised surfaces may occur during building. Painters may accidentally splash paint on newly installed windows and doors, marring their appearance. The cleaner must act quickly and remove such splashes with a soft cloth moistened with water. Using water based paints allows the cleaner to clean with water - using solvents may put your hardware at risk.

### CARE AND MAINTENANCE OF STAINLESS STEEL

Stainless steel is used for fittings and hardware by Metro Frameless Glass (MFG) for its strength, aesthetics, and its inherent high level of corrosion resistance. MFG uses predominately 316 Grade Stainless Steel (also known as Marine Grade stainless) hardware for external applications such as balustrades, pool fences, canopies and spider walls, but many of the entry door patch fittings and handles use 304 Grade. In some special cases the higher strength 2205 duplex grade is used by MFG. The design of our frameless glass systems and installation techniques are intended to make the systems as maintenance free as possible, but there are still maintenance procedures, associated with any exposed structure, that must not be overlooked. Stainless Steel is called so as it is less prone to staining. It is important to recognize that the material is not impervious to mild staining or even corrosion in some instances. The likelihood and severity of staining is a product of exposure to marine salts and other corrosive materials which can affect installations even 20km inbound from coastal areas. Pollen and other airborne matter can also contribute to corrosion so there no areas of New Zealand where the topic can be ignored. The smoother the surface is, the less prone to discoloration.

Stainless steel may be discoloured from corrosion;

- If used in areas where rain does not wash the fittings.
- If it is exposed to a more aggressive environment than that for which the particular grade of steel is intended, e.g. highly polluted air, salt solutions or residues of cleaning agents containing chlorine.
- If it has a rough surface that enables a corrosive substance to adhere to.
- If the fittings are not cleaned after installation and have oil/acid from hands.
- If the design of the steel component has crevices and narrow gaps.
- If the surface is contaminated or damaged by grinding swarf or other iron particles from tools used in the installation work.
- If fasteners of ordinary steel or dissimilar metals are used for securing the hardware, or if the hardware comes into direct contact with adjacent components made of plain carbon steel in wet or humid conditions (galvanic corrosion).

Light corrosion is often referred to as “Tea Staining” as it is a brown surface discolouration which, although not affecting the material structurally, is none the less unsightly. The likelihood of this occurring can be greatly reduced through the use of 316 Grade, regular cleaning and the use of protective coatings.

## POSIGLAZE CARE & MAINTENANCE GUIDE (Page 04)

The following guidelines apply;

- j. Any stainless steel hardware should be cleaned after installation and before any glass is installed.
- k. Basic cleaning can be carried out using simple soap solutions or mild detergents applied with warm water (or proprietary cleaners) and a clean non-abrasive cloth. The solution should be thoroughly rinsed off with cold water, and wiped dry with a clean absorbent cloth. Isopropyl alcohol can also be used to clean finger and hand marks.
- l. Avoid bleach, as this can mark the metal surface, and avoid any abrasive applicators - especially a ferrous based cleaning pad, such as steel wool, as this can introduce contamination which reacts with the stainless steel and makes corrosion worse.
- m. Protective coatings are also available that can be easily applied to the hardware which can increase maintenance periods. Information regarding these products is available from MFG. Stainless steel hardware should be cleaned again during the final clean and if possible after any surrounding building work is complete.
- n. If mild tea staining has already occurred, a plastic abrasive pad - "Scotchbrite" for example - can be used, again with warm water and a mild detergent / soap solution. When abrading however, it is important to only rub in one direction which is the same direction as any visible brushed finish. Take care to only rub the steel components, not the glass. A stainless steel rejuvenating paste can also be used and works well in combination with a scotchbrite pad. Information regarding these products is available from MFG.
- o. When installation is complete the frequency of a regular cleaning regime will vary according to the installation design and level of exposure, especially in regard to proximity to the sea. In general cleaning should take place 3 to 4 times a year. Protective coatings can prolong the maintenance interval.

Environment	Washing Intervals	
	316 Grade	304 Grade
Clean inland location	6 - 12 months	3 - 6 months
Polluted urban and industrial	6 - 12 months	Unsuitable
Coastal atmosphere	3 - 6 months	Unsuitable

### Recommended cleaning methods:

Washing Intervals	Washing Intervals	Washing Intervals
<b>Routine cleaning</b> (this is important in Coastal areas)	Soap or detergent and warm water. Or proprietary stainless steel cleaners. Sponge with cloth or soft brush then rinse with clean water and dry.	Satisfactory on all surfaces. Situations directly on the seafront are best if cleaning monthly. Uneven surfaces or surfaces with crevices are prone to trapping corrosion agents.
<b>Fingerprints</b>	Detergent and warm water or organic solvent. Or proprietary stainless steel cleaners.	Satisfactory on all surfaces. To minimise recurrence use a protective coating.
<b>Oil and Grease Marks</b>	Organic solvent, e.g. acetone	
<b>Stubborn Spots Stains Light Discolouration Hard Water Spots Scale and General Water Marks</b>	Mild abrasive detergents rinse and dry.	Use a stainless steel rejuvenating paste and protective coating.
<b>Heavy Discolouration</b>	Mild abrasive detergents rinse and dry. A plastic abrading pad and or paste can be used with care.	Use a stainless steel rejuvenating paste and protective coating.

In summary:

- Cleaning should be thorough and at a frequency to suit the environment
- Wash with warm water and mild detergent or soap solution or use proprietary stainless steel cleaners.
- Rinse thoroughly with clean cold water and dry.
- Do not use harsh abrasive cleaners and especially no wire wool or similar ferrous scourers.
- If mild corrosion is present, then a mild abrasive detergent or rejuvenating paste can be used with a warm mild solution and fully rinsed with clean cold water.
- Heavier levels of staining can be removed with a light plastic abrading pad (such as Scotchbrite) rubbing must only be in one direction with that being as per any visible surface finish. This is best done with a rejuvenating paste Use protective coatings after cleaning
- Be careful to ensure cleaners do not effect fibre or other fitting gasket materials



### CARE AND MAINTENANCE OF HANDLES / MECHANISMS

Periodic maintenance of handles / mechanisms is essential, this includes locks, handles, hinges, levers, rollers, bolts, etc. This applies particularly to mechanisms with moving parts that require lubrication. Before doing any cleaning or maintenance, you must establish exactly what hardware has been installed and how it has been constructed.

Lubrication for Mechanisms;

Mechanisms include hinges, cylinders, locks, rollers and fasteners. You can keep these mechanisms in good working order through regular cleaning and lubrication.

- p. MPG recommend a Teflon-based lubricate or please refer to the manufacturer's care instructions. A soft bristle brush can be used on exposed parts. Apply Teflon-based lubricate to the moving parts - you don't need to use very much. This will limit corrosion of the exposed metals. MPG advise to do this once every two months. If, however your hardware is near the sea or exposed to salt air, we recommend you lubricate the components once every month.

Electrical Entrance Systems;

Do not let the product get wet.

- q. Keep clear of debris and general dirt.
- r. Wipe the keypads or swipe the device with a clean damp cloth.
- s. Do NOT use solvents.
- t. Replacement batteries will be required.

### SCRATCHES AND METAL SCRAPERS

Scratches can occur from hard pointed objects or poor handling, but most often occurs from the careless removal of foreign matter from the glass surface. Mortar splatter and paint are common offenders and efforts to remove after hardening almost always lead to surface damage.

- u. It is essential that the foreign materials are removed before they harden. Better still, if construction work continues after glazing, that the glazed areas are protected by adhesive plastic films or suitable covers.
- v. One of the common mistakes made by non-glass trades people, including glass cleaning contractors, is the use of razor blades or other metal scrapers on a large portion of the glass surface. Using large blades to scrape a window clean carries considerable risk of causing damage to the glass.
- w. The glass industry, fabricators, distributors and installers neither condones nor recommends any scraping of glass surfaces with metal blades or knives. Such scraping usually permanently damages or scratches the glass surfaces.
- x. When paint or other construction materials cannot be removed with normal cleaning procedures, a new 25mm razor blade may have to be used. The razor blade should be used on small spots only. Cleaning should be done in one direction only. Never scrape in a back and forth motion as this could trap particles under the blade that could scratch the glass. Blades or scrapers can dislodge "pickup" on toughened and heat strengthened glass. There are fine particles of glass that are fused on to the surface during toughening. Once dislodged they can scratch the glass.

### ONSITE CONSTRUCTION / INSTALLATION PROTECTION

Hardware Protection during Installation:

- y. All the activity on a construction site means that your hardware items may get knocked or scratched, splattered with mortar, plaster, textured coating or paint during the later stages of construction.
- z. Please ensure that all hardware articles are masked or covered at this time. It is far easier to prevent accidents than to try and correct them. Should your hardware receive mortar or paint splashes see that these are removed before cure and follow the instructions outlined above.

**For further information, please refer to the PS1 or MPG instructions and guidelines on our websites.**